

Crane kit



A complete crane in an
"All round-Carefree-Package",
Power – out of the box

- Minimum headroom
- Individual solutions based on standardised components
- Variable trolley and crane movement
- Minimum load sway
- Reduced maintenance and downtime
- State-of-the-art inverter technology as standard for trolleys and cranes, minimising wear on the drive units
- High efficiency
One-Stop-Shopping principle: All components from one source
- Shorter assembly times
Pre-designed, pre-assembled and pre-wired components with screw and plug connection
- Numerous different versions
A well planned standard component basis, crane calculation support via CraneMaster software
- Reliable quality
High performance hoists, robust crane components

Complete component kits for:

- Single-girder bridge cranes
- Double-girder bridge cranes
- Single-girder underslung cranes
- For wire rope or chain hoists
- Capacities up to 80t

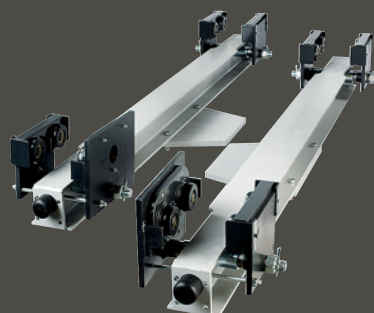
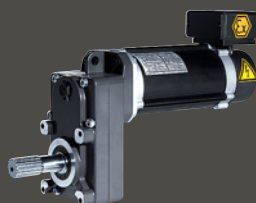

Custom-made component kits for bridge cranes



State-of-the-art crane design.

All SWF components are manufactured according to the most stringent quality standards and thoroughly tested. No detail has slipped our attention and the components are preassembled. Installation is thus made easy and you can rest assured that everything works as it should.

SWF develops special components for cranes. IP55 protection and insulation class F are standard. Both the gear and motor design are based on what is technically possible today. By using SWF components, you achieve the best compatibility and quality.

CraneMaster – Sophisticated crane configuration software.

CraneMaster will improve the competitiveness of your crane, monorail system and crane components at the projecting stage. Optimised processing and reliable information flow allows CraneMaster to produce exact Microsoft compatible technical solutions at the best possible price, whether it be an offer, order confirmation, technical data sheet or technical layout drawing, CraneMaster can provide this information within a matter of minutes. The vast, constantly updated component data bank, comprising of electric wire rope hoists, chain hoists, end carriages, travelling machineries, electric components, frequency inverters and radio control systems will always give the optimum solution.

Crane kit

Powerful hoists



SK FNU
with motor trolley drive
up to 5,000 kg



NOVA L
Single girder trolley,
low headroom, up to 12,5t



NOVA N
Single girder trolley,
normal headroom, up to 40t



NOVA M 
Double girder trolley,
explosion proof, up to 80t

Electric chain hoist SK up to 5,000 kg

- Compact headroom
- Robust industrial design
- 2 lifting speeds (4/1), optionally with frequency inverter for step less hoisting
- Upper and lower hoisting limit switch
- Drive operation with frequency inverter
- Mechanical overload protection
- Explosion proof version as option 
- Versions for the food industry as option



Electric wire rope hoist NOVA up to 80 t

- Compact design and optimum approach dimensions
- Minimum hook movement
- Lifting heights up to more than 100 m
- 2-speed hoisting motors (6/1), optionally with frequency inverter for step less hoisting
- 4-step hoisting limit switch with slow-down function and phase mismatch protection
- Travelling machineries with frequency inverter, 2-speed or variable
- Optional with hoist monitoring system NovaMaster and lifting inverter HoistMaster, also for synchronized use
- Explosion proof version as option 



For loads up to 80t



Crane kits by SWF include:

- Plug-in adapters and couplings for all components
- Completely wired standard and custom made electrical components
- Numerous options available like tandem use, anti-collision device, rain cover, radio remote control, hoist monitoring, digital load display, etc.
- Modular crane kits assembled according to your specifications
- Continuous quality control from the first drawing to the final package
- Project support with CraneMaster

The crane kit component package contains for example:

- | | |
|---|---------------------------------|
| 1 Hoist power supply with flat cable | 10 Load LED display |
| 2 Hoist power supply with energy chain | 11 Bridge panel |
| 3 Control pendant with EMERGENCY-STOP, display as option | 12 Crane light for bridge |
| 4 Radio remote control including transmitter and receiver | 13 Crane power towing arm |
| 5 Backup pendant | 14 Flashing light |
| 6 Electric hoist | 15 Horn |
| 7 Hoist power towing arm | 16 End carriages |
| 8 Trolley and crane travelling limit switch | 17 Crane travelling machineries |
| 9 Trolley end stop assembly | |

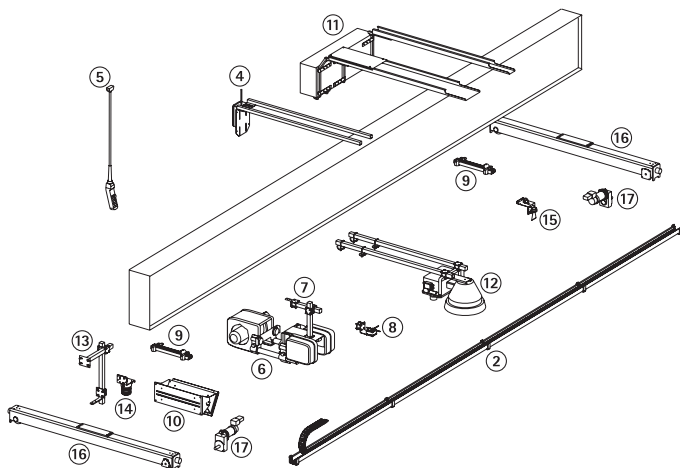

Single-girder bridge crane with energy chain and radio remote control

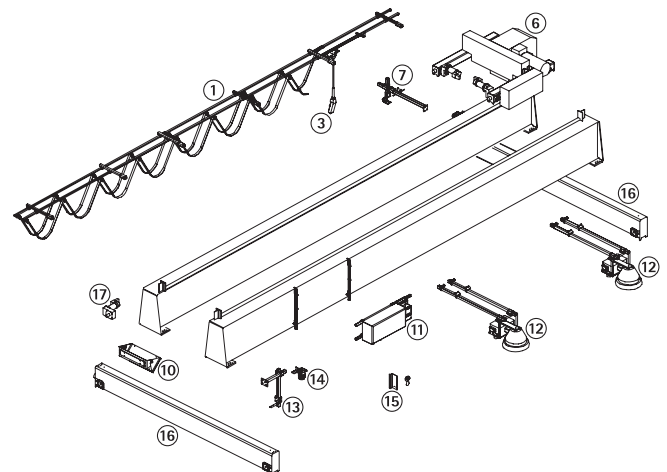

Double-girder bridge crane with flat cable and control pendant

Look ahead!



ENGLISH

SWF Krantechnik GmbH

Postfach 310410
D-68264 Mannheim
Germany

Boehringer Str. 4
D-68307 Mannheim
Germany

Phone +49(0)621.78990-0
Fax +49(0)621.78990-100

info.de@swfkrantechnik.com
www.swfkrantechnik.com