

Drum brakes SL according to DIN 15435

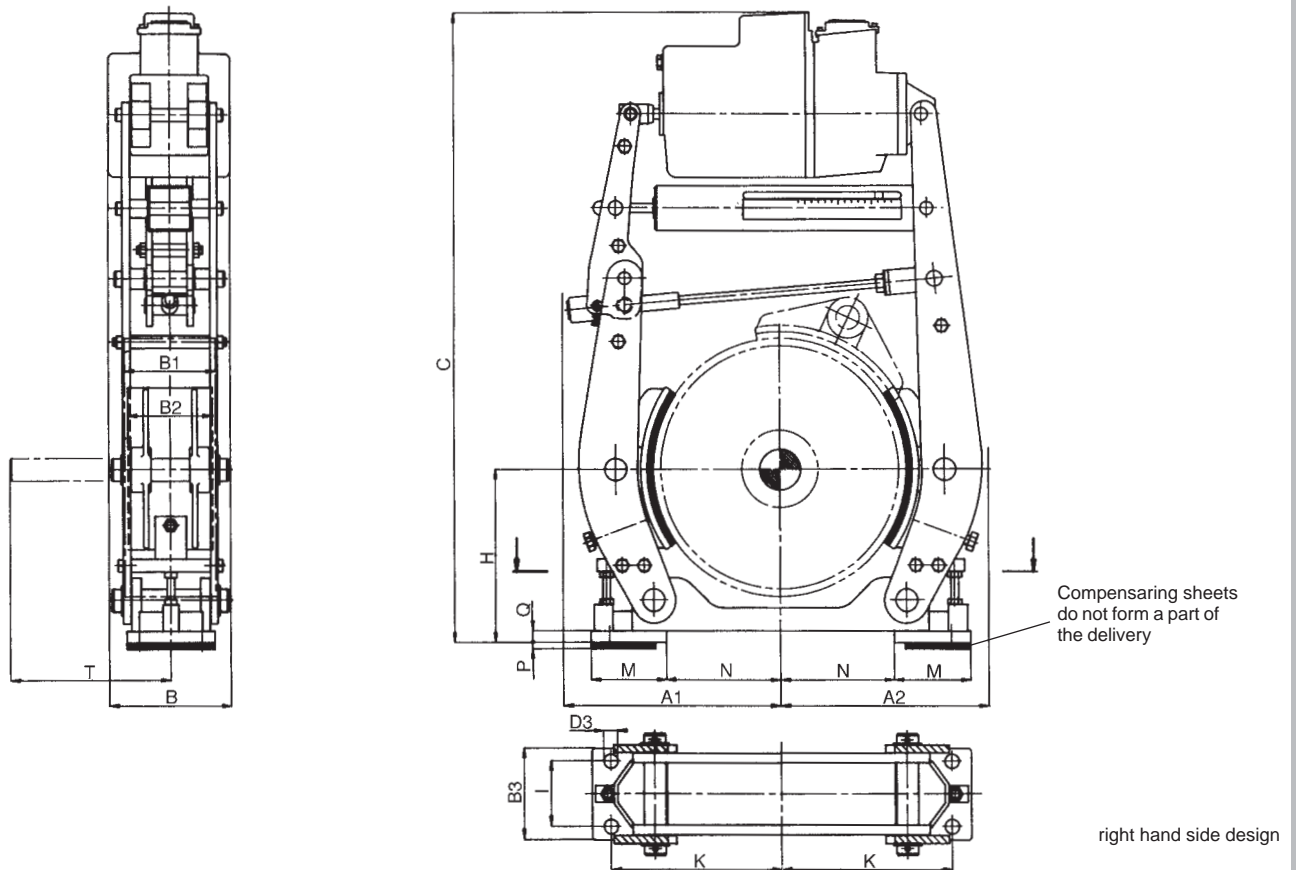

Technical Datas: ³⁾

All data subject to change without notice

D 1	Thruster-size	M_{Br} [Nm] ^{1) 4) 5)}		$A1_{max}$	$A2_{max}$	B_{max}	C_{max}	B1	B2	B3	D3	H	I	K	M	N	P	Q	T	Weight app.kg ²⁾
		$\mu = 0,3$	$\mu = 0,4$																	
200	23/5	75- 230	100- 300	235	190	162	730	75	70	80	14	155	55	145	90	85	5	10	155	24
	30/5	75- 300	100- 400	260	230															
250	23/5	75- 230	100- 300	260	210	162	810	95	90	100	18	185	65	180	100	105	5	13	172	33
	30/5	75- 310	100- 410	260	245	160	785													
315	23/5	90- 280	120- 370	315	265	162	880													45
	30/5	90- 395	120- 520	315	265	160	880	118	110	110	18	225	80	220	110	135	5	13	208	45
	50/6	260- 700	350- 900	320	285	195	925													47
	80/6	260-1200	350-1600	320	285	205	925													47
400	30/5	115- 400	150- 520	325	325	190	970													60
	50/6	260- 700	350- 920	325	325	195	1005	150	140	140	22	270	100	270	120	180	10	18	252	62
	80/6	260-1200	350-1600	325	325	205	1005													62
	121/6	380-1930	500-2550	445	390	240	1105													90
500	50/6	380- 930	500-1230	405	395	250	1245	190	180	180	22	330	130	325	140	220	10	18	315	125
	80/6	380-1550	500-2050	405	395															
	121/6	570-2400	750-3180	425	400															
	201/6	760-3750	1000-4950	425	400															
630	121/6	745-2350	1000-3100	470	470	300	1400	236	225	220	27	410	170	400	160	285	10	22	390	185
	201/6	745-3700	1000-4900																	185
	301/6	1100-5700	1500-7500																	190
710	121/6	1100-2700	1500-3550	530	530	325	1485	265	255	240	27	460	190	450	180	320	10	22	430	235
	201/6	1100-4200	1500-5500																	235
	301/6	1500-6450	2000-8500																	240

¹⁾ Value lower than the minimum stated on request ⁴⁾ The various operating conditions like circumferential (sliding) speed, contact pressure, thermal load, material of the brake disc and environment influences can change the friction value. It should be taken into consideration when calculating a brake.
²⁾ Without thruster
³⁾ Dimensions in mm
⁵⁾ Recommendation: necessary Braking torque between 30% and 90% of the maximum value

Ausgabe 3/96



SHB Saalfelder
Hebezeugbau GmbH
Unternehmensbereich Komponenten

Phone: +49 36 71 44 1-341

44 1342

Fax: +49 36 71 44 1-343

E-mail: komponenten@shb-net.de