

# TECHNICAL GUIDE; CHARACTERISTICS

## *Characteristics (SI/50Hz)*

SI

6.7.2010

- - - -

### **SWF Krantechnik GmbH**

Postbox 310410  
68264 Mannheim  
Germany

Boehringer Straße 4  
68307 Mannheim  
Germany

tel +49(0)621 789-900  
fax +49(0)621 789 90-100  
Info@swfkrantechnik.com  
www.swfkrantechnik.com

Original instructions

English

03/08/2010

1 / 71

This document and the information contained herein, is the exclusive property of SWF Krantechnik GmbH and represents a non-public, confidential and proprietary trade secret that may not be reproduced, disclosed to third parties, altered or otherwise employed in any manner whatsoever without the express written consent of SWF Krantechnik GmbH. Copyright © (2010) SWF Krantechnik GmbH. All rights reserved.

Table of content

1	HOIST STANDARD FEATURES .....	3
1.1	NB Standard features .....	3
1.2	NC Standard features.....	4
1.3	ND Standard features.....	5
1.4	NE Standard features .....	6
1.5	NF Standard features .....	7
1.6	SWF code example (SWF: Nova, Factory: Q) .....	8
2	TECHNICAL CHARACTERISTICS .....	9
3	HOISTING MOTORS .....	28
3.1	Motor data, 2 - speed pole change motors, 50 Hz.....	28
3.2	Motor currents, 2 - speed pole change motors, 50 Hz.....	31
3.3	Motor data, 2 - speed pole change motors, 60 Hz.....	33
3.4	Motor currents, 2 - speed pole change motors, 60 Hz.....	36
3.5	Motor data, inverter motors, 100 Hz.....	38
3.6	Motor data, inverter motors, 120 Hz.....	40
3.7	Motor currents, inverter motors, 100 Hz and 120 Hz .....	42
3.8	Motor data, one speed motors, 50 Hz.....	44
3.9	Motor currents, one speed motors, 50 Hz.....	45
3.10	Motor data, one speed motors, 60 Hz .....	46
3.11	Motor currents, one speed motors, 60 Hz .....	47
4	TRAVELLING MOTORS .....	48
4.1	One speed, 3000 RPM (100 Hz), 3600 RPM (120 Hz) and 4800 RPM (80Hz).....	48
4.2	Two speed, 3000/750 RPM (50Hz) and 3600/900 RPM (60Hz).....	51
4.3	One speed, 3000 RPM (50Hz) and 3600 RPM (60Hz).....	54
5	TROLLEY SPEED TABLES .....	55
5.1	Inverter control(T), Speed range .....	55
6	SURFACE TREATMENT .....	60
6.1	Standard painting system.....	60
6.2	Color codes .....	60
7	WIRE ROPE DATA .....	61
8	MATERIALS.....	62
9	HOOK.....	67
9.1	Hook block dimensions .....	67
9.2	Hook block dimensions .....	68
9.3	Hook forging dimensions.....	69
10	DRUM AND ROPE SHEAVE DIAMETERS.....	70

# 1 HOIST STANDARD FEATURES

## 1.1 NB Standard features

Features for...	
Hoisting	<input type="checkbox"/> Mechanical limit switch as overload protector <input type="checkbox"/> 4-step hoisting limit switch (hook low, hook up slow down, stop and phase mismatch protection)
Hoist motor	<input type="checkbox"/> Two-speed pole-change hoisting motor, 6:1 speed ratio <input type="checkbox"/> 60 % ED <input type="checkbox"/> F class insulation <input type="checkbox"/> IP55 protection <input type="checkbox"/> Klixon type bimetal switch for thermal protection
Hook	<input type="checkbox"/> 2-roped: Hook forging strength class V DIN15400, size RSN1 DIN15401 <input type="checkbox"/> 4-roped: Hook forging strength class V DIN15400, design HBC with hand grip, size min. 1.6 (DIN15401) <input type="checkbox"/> Safety latch
Rope reeving	<input type="checkbox"/> EN-GJS-700-3 cast iron rope guide incl. pressure roll for slack rope protection. Machinery hoists: pressure bar along the drum to hold the rope <input type="checkbox"/> EN-GJS-500-7 rope sheaves <input type="checkbox"/> Rope sheave / rope diameter ratio according to ISO M6 duty class as minimum
Travelling	<input type="checkbox"/> Low headroom trolley flange width range 80–410 mm. <i>Factory settings max. width or package size</i> <input type="checkbox"/> Normal headroom trolley flange width range 80–450 mm <input type="checkbox"/> Medium double girder trolley rail gauges 1200, 1400, 1700, 2000 mm <input type="checkbox"/> High mounted double girder trolley rail gauge 900, 1200, 1400, 1700, 2000 mm <input type="checkbox"/> One travel motor in trolley. In N-trolley the amount depends on reeving system <input type="checkbox"/> EN-GJS-500-7 cast iron flanged rail wheels, 2 driven by travelling machinery. The wheel groove width is 65 mm as standard for double girder trolley <input type="checkbox"/> 4 pcs rubber buffers <input type="checkbox"/> Jump-off protection in single girder trolleys (N, L) <input type="checkbox"/> Axle failure protection in both double and single girder trolleys
Travel machinery	<input type="checkbox"/> Frequency converter motor with compact brake, DMCS controller in hoist panel <input type="checkbox"/> Two adjustable speeds with ramp functions min. 5 m/min, max. 20 m/min (MS2-control). <i>Factory settings 20 / 5.</i> <input type="checkbox"/> 40 % ED
Electrical outfit	<input type="checkbox"/> Standard 3-phase voltages 50Hz: 220V*, 230V*, 240V*, 380V, 400V, 415V, 500V*, 525V* <input type="checkbox"/> Standard 3-phase voltages 60Hz: 220V*, 230V*, 240V*, 440V, 460V, 480V, 575V*, 600V* <input type="checkbox"/> (*additional price and delivery time) <input type="checkbox"/> Standard control voltages 48V / 50Hz, 115V / 50Hz or 60Hz, 230V / 50Hz or 60Hz <input type="checkbox"/> Assembly according to IEC standards <input type="checkbox"/> IP 55 / NEMA 4 steel control panel <input type="checkbox"/> Electrics for single hoist use in crane application (main contactor nor control voltage transformer not included) <input type="checkbox"/> Plug in connectors for power supply and control cables
Environment	<input type="checkbox"/> Ambient temperature –10 °C...+40°C
Surface treatment	<input type="checkbox"/> Epoxy paint. Thickness 100/120 µ (Powder/Wet painting) for load carrying parts
Marking	<input type="checkbox"/> Hoist type plate incl. CE mark <input type="checkbox"/> Rope code sticker <input type="checkbox"/> Hoist stickers: brand name and type designation <input type="checkbox"/> Hook stickers: brand name and load
Documents	<input type="checkbox"/> 1 pcs Hoist Owner's Manual <input type="checkbox"/> Hoist test certificate <input type="checkbox"/> Wire rope certificate <input type="checkbox"/> Hook certificate
Delivery	<input type="checkbox"/> Enclosed plywood box length 1530 mm x width 780 mm x height 570 mm for L and N –trolleys <input type="checkbox"/> Wooden grate packing for double girder trolleys. Size according to the trolley <input type="checkbox"/> Anticorrosion plastics around the hoist

## 1.2 NC Standard features

Features for...	
Hoisting	<input type="checkbox"/> Mechanical limit switch as overload protector <input type="checkbox"/> 4-step hoisting limit switch (hook low, hook up slow down, stop and phase mismatch protection)
Hoist motor	<input type="checkbox"/> Two-speed pole-change hoisting motor, 6:1 speed ratio <input type="checkbox"/> 60 % ED <input type="checkbox"/> F class insulation <input type="checkbox"/> IP55 protection <input type="checkbox"/> Klixon type bimetal switches for thermal protection
Hook	<input type="checkbox"/> 2-roped: Hook forging strength class V DIN15400, size RSN1 DIN15401 <input type="checkbox"/> 4-, 6- and 8-roped: Hook forging strength class V DIN15400, design HBC with hand grip, size min. 2.5 (DIN15401) <input type="checkbox"/> Safety latch
Rope reeving	<input type="checkbox"/> EN-GJS-700-3 cast iron rope guide incl. pressure roll for slack rope protection. Machinery hoists: pressure bar along the drum to hold the rope <input type="checkbox"/> EN-GJS-500-7 rope sheaves <input type="checkbox"/> Rope sheave / rope diameter ratio according to ISO M6 duty class as minimum
Travelling	<input type="checkbox"/> Low headroom trolley flange width range 100–490 mm. <i>Factory settings max. width or the package size</i> <input type="checkbox"/> Normal headroom trolley flange width range 80 – 450 mm <input type="checkbox"/> Medium double girder trolley rail gauges 1200, 1400, 1700, 2000 mm (depends on H.O.L.) <input type="checkbox"/> High mounted double girder trolley rail gauge 900, 1200, 1400, 1700, 2000 mm <input type="checkbox"/> One travel motor in trolley. In N-trolley the amount depends on reeving system <input type="checkbox"/> EN-GJS-500-7 cast iron flanged rail wheels, 2 driven by travelling machinery. The wheel groove width is 65 mm as standard for double girder trolley <input type="checkbox"/> 4 pcs rubber buffers <input type="checkbox"/> Jump-off protection in single girder trolleys (N, L) <input type="checkbox"/> Axle failure protection in both double and single girder trolleys
Travel machinery	<input type="checkbox"/> Frequency converter motor with compact brake, DMCS controller in hoist panel <input type="checkbox"/> Two adjustable speeds with ramp functions min. 5 m/min, max. 20 m/min (MS2-control). <i>Factory settings 20 / 5</i> <input type="checkbox"/> 40 % ED
Electrical outfit	<input type="checkbox"/> Standard 3-phase voltages 50Hz: 220V*, 230V*, 240V*, 380V, 400V, 415V, 500V*, 525V* <input type="checkbox"/> Standard 3-phase voltages 60Hz: 220V*, 230V*, 240V*, 440V, 460V, 480V, 575V*, 600V* <input type="checkbox"/> (*additional price and delivery time) <input type="checkbox"/> Standard control voltages 48V / 50Hz, 115V / 50Hz or 60Hz, 230V / 50Hz or 60Hz <input type="checkbox"/> Assembly according to IEC standards <input type="checkbox"/> IP 55 steel control panel <input type="checkbox"/> Electrics for single hoist use in crane application (main contactor or control voltage transformer not included) <input type="checkbox"/> Plug in connectors for power supply and control cables
Environment	<input type="checkbox"/> Ambient temperature –10 °C...+40°C
Surface treatment	<input type="checkbox"/> Epoxy paint. Thickness 100/120 µ (Powder/Wet painting) for load carrying parts
Marking	<input type="checkbox"/> Hoist type plate incl. CE mark <input type="checkbox"/> Rope code sticker <input type="checkbox"/> Hoist stickers: brand name and type designation <input type="checkbox"/> Hook stickers: brand name and load
Documents	<input type="checkbox"/> 1 pcs Hoist Owner's Manual <input type="checkbox"/> Hoist test certificate <input type="checkbox"/> Wire rope certificate <input type="checkbox"/> Hook certificate
Delivery	<input type="checkbox"/> Wooden grate packing. Size according to the trolley <input type="checkbox"/> Anticorrosion plastics around the hoist

### 1.3 ND Standard features

Features for...	
Hoisting	<input type="checkbox"/> Mechanical limit switch as overload protector <input type="checkbox"/> 4-step hoisting limit switch (hook low, hook up slow down, stop and phase mismatch protection)
Hoist motor	<input type="checkbox"/> Two-speed pole-change hoisting motor, 6:1 speed ratio <input type="checkbox"/> 60 % ED <input type="checkbox"/> F class insulation <input type="checkbox"/> IP55 protection <input type="checkbox"/> Klixon type bimetal switches for thermal protection
Hook	<input type="checkbox"/> Hook forging strength class V DIN15400 <input type="checkbox"/> Hook forging design HBC with handgrip, 4-roped size min. 5.0 (DIN15401), 2-roped models size min. 2.5 <input type="checkbox"/> 6- and 8-roped models with forging type RSN6 (DIN15401) <input type="checkbox"/> Safety latch
Rope reeving	<input type="checkbox"/> EN-GJS-700-3 cast iron rope guide incl. pressure roll for slack rope protection. Machinery hoists: pressure bar along the drum to hold the rope <input type="checkbox"/> EN-GJS-500-7 rope sheaves <input type="checkbox"/> Rope sheave / rope diameter ratio according to ISO M6 duty class as minimum
Travelling	<input type="checkbox"/> Low headroom trolley flange width range 100 – 610 mm. <i>Factory settings max. width or package size</i> <input type="checkbox"/> Normal headroom trolley flange width ranges 04/02-roped 80–610 mm, 06/08-roped 80-610 mm <input type="checkbox"/> Medium double girder trolley rail gauges 1400, 1700, 2000, 2400 mm (depends on H.O.L. and rope reeving) <input type="checkbox"/> High mounted double girder trolley rail gauge 1200, 1400, 1700, 2000, 2400 mm <input type="checkbox"/> Low double girder trolley rail gauges 1400, 1700, 2000 mm (depends on H.O.L. ) <input type="checkbox"/> Two travel motors in double girder trolley. In N-trolley the amount depends on reeving system <input type="checkbox"/> EN-GJS-500-7 cast iron flanged rail wheels, groove width 65 mm, 2 driven by travelling machineries <input type="checkbox"/> EN-GJS-500-7 cast iron flanged rail wheels, 2 driven by travelling machinery. The wheel groove width is 65 mm as standard for double girder trolley <input type="checkbox"/> 4 pcs rubber buffers <input type="checkbox"/> Jump-off protection in single girder trolleys (N, L) <input type="checkbox"/> Axle failure protection in both double and single girder trolleys
Travel machinery	<input type="checkbox"/> Frequency converter motor with compact brake, DMCS controller in hoist panel <input type="checkbox"/> Two adjustable speeds with ramp functions min. 5 m/min, max. 20 m/min (MS2-control). <i>Factory settings 20 / 5</i> <input type="checkbox"/> 40 % ED
Electrical outfit	<input type="checkbox"/> Standard 3-phase voltages 50Hz: 220V*, 230V*, 240V*, 380V, 400V, 415V, 500V*, 525V* <input type="checkbox"/> Standard 3-phase voltages 60Hz: 220V*, 230V*, 240V*, 440V, 460V, 480V, 575V*, 600V* <input type="checkbox"/> (*additional price and delivery time) <input type="checkbox"/> Standard control voltages 48V / 50Hz, 115V / 50Hz or 60Hz, 230V / 50Hz or 60Hz <input type="checkbox"/> Assembly according to IEC standards <input type="checkbox"/> IP 55 / NEMA 4 steel control panel <input type="checkbox"/> Electrics for single hoist use in crane application (main contactor or control voltage transformer not included) <input type="checkbox"/> Plug in connectors for power supply and control cables
Environment	<input type="checkbox"/> Ambient temperature –10 °C...+40°C
Surface treatment	<input type="checkbox"/> Epoxy paint. Thickness 100/120 µ (Powder/Wet painting) for load carrying parts
Marking	<input type="checkbox"/> Hoist type plate <input type="checkbox"/> Rope code sticker <input type="checkbox"/> Hoist stickers: brand name and type designation <input type="checkbox"/> Hook stickers: brand name and load
Documents	<input type="checkbox"/> 1 pcs Hoist Owner's Manual <input type="checkbox"/> Hoist test certificate <input type="checkbox"/> Wire rope certificate <input type="checkbox"/> Hook certificate
Delivery	<input type="checkbox"/> Wooden grate packing. Size according to the trolley <input type="checkbox"/> Anticorrosion plastics around the hoist

## 1.4 NE Standard features

Features for...	
Hoisting	<input type="checkbox"/> Mechanical limit switch as overload protector <input type="checkbox"/> 4-step hoisting limit switch (hook low, hook up slow down, stop and phase mismatch protection)
Hoist motor	<input type="checkbox"/> Two-speed pole-change hoisting motor, 6:1 speed ratio <input type="checkbox"/> 60 % ED <input type="checkbox"/> F class insulation <input type="checkbox"/> IP55 protection <input type="checkbox"/> Klixon type bimetal switches for thermal protection
Hook	<input type="checkbox"/> Load max. 20 t: Hook forging strength class V DIN15400, hook forging design HBC with hand grip, size min. 5.0 (DIN15401) <input type="checkbox"/> Load over 20 t: Hook forging strength class T DIN15400, size RSN10 (6- or 2x6-ropes) or RSN16 (8- or 2x8-ropes) DIN15401 <input type="checkbox"/> Safety latch
Rope reeving	<input type="checkbox"/> EN-GJS-700-3 cast iron rope guide. Machinery hoists: pressure bar along the drum to hold the rope <input type="checkbox"/> EN-GJS-500-7 rope sheaves <input type="checkbox"/> Rope sheave / rope diameter ratio according to ISO M6 duty class as minimum
Travelling	<input type="checkbox"/> Normal headroom trolley flange width ranges 2-roped 120-610 mm, 4- and 6-roped 120 – 610 mm , 8-roped 250-610 mm. <input type="checkbox"/> Medium double girder trolley rail gauges 1700, 2000, 2400, 2700, 3100, 3400, 3800 and 4200 mm (depends on H.O.L. and rope reeving) <input type="checkbox"/> Two travel motors in double girder trolley. In N-trolley the amount depends on reeving system <input type="checkbox"/> EN-GJS-500-7 cast iron flanged rail wheels, groove width 65 mm, 2 driven by travelling machineries <input type="checkbox"/> 4 pcs rubber buffers <input type="checkbox"/> Jump-off and axle failure protection in single girder trolleys (trolley type N)
Travel machinery	<input type="checkbox"/> Frequency converter motor, inverter controller in hoist panel <input type="checkbox"/> Two adjustable speeds with ramp functions min. 5 m/min, max. 20 m/min (MS2-control) <i>Factory settings 20 / 5.</i> <input type="checkbox"/> 40 % ED
Electrical outfit	<input type="checkbox"/> Standard 3-phase voltages 50Hz: 220V*, 230V*, 240V*, 380V, 400V, 415V, 500V*, 525V* <input type="checkbox"/> Standard 3-phase voltages 60Hz: 220V*, 230V*, 240V*, 440V, 460V, 480V, 575V*, 600V* <input type="checkbox"/> (*additional price and delivery time) <input type="checkbox"/> Standard control voltages 48V / 50Hz, 115V / 50Hz or 60Hz, 230V / 50Hz or 60Hz <input type="checkbox"/> Assembly according to IEC standards <input type="checkbox"/> IP 55 / NEMA 4 steel control panel <input type="checkbox"/> Electrics for single hoist use in crane application (main contactor or control voltage transformer not included) <input type="checkbox"/> Plug in connectors for power supply and control cables
Environment	<input type="checkbox"/> Ambient temperature -10 °C...+40°C
Surface treatment	<input type="checkbox"/> Epoxy paint. Thickness 100/120 µ (Powder/Wet painting) for load carrying parts
Marking	<input type="checkbox"/> Hoist type plate <input type="checkbox"/> Rope code sticker <input type="checkbox"/> Hoist stickers: brand name and type designation <input type="checkbox"/> Hook stickers: brand name and load
Documents	<input type="checkbox"/> 1 pcs Hoist Owner's Manual <input type="checkbox"/> Hoist test certificate <input type="checkbox"/> Wire rope certificate <input type="checkbox"/> Hook certificate
Delivery	<input type="checkbox"/> Wooden grate packing. Size according to the trolley <input type="checkbox"/> Anticorrosion plastics around the hoist

## 1.5 NF Standard features

Features for...	<input type="checkbox"/>
Hoisting	<input type="checkbox"/> Mechanical limit switch as overload protector <input type="checkbox"/> 4-step hoisting limit switch (hook low, hook up slow down, stop and phase mismatch protection)
Hoist motor	<input type="checkbox"/> 2 pcs two-speed pole-change hoisting motor, 6:1 speed ratio <input type="checkbox"/> 60 % ED <input type="checkbox"/> F class insulation <input type="checkbox"/> IP55 protection <input type="checkbox"/> Klixon type bimetal switches for thermal protection
Hook	<input type="checkbox"/> Load max. 20 t: Hook forging strength class V DIN15400, hook forging design HBC with hand grip, size min. 5.0 (DIN15401) <input type="checkbox"/> Load over 20 t: Hook forging strength class T DIN15400, size RSN16 (2x4-roped), RSN20 (2x6-roped) or RSN25 (2x8 roped) DIN15401 <input type="checkbox"/> Safety latch
Rope reeving	<input type="checkbox"/> True vertical rope reeving <input type="checkbox"/> EN-GJS-700-3 cast iron rope guide. Machinery hoists: pressure bar along the drum to hold the rope <input type="checkbox"/> EN-GJS-500-7 rope sheaves <input type="checkbox"/> Rope sheave / rope diameter ratio according to ISO M6 duty class as minimum
Travelling	<input type="checkbox"/> Medium double girder trolley rail gauges 1700, 2000, 2400, 2700, 3100, 3400, 3800 and 4200 mm (depends on H.O.L. and rope reeving) <input type="checkbox"/> Two travel motors in trolley <input type="checkbox"/> EN-GJS-500-7 cast iron flanged rail wheels, groove width 65 mm, 2 driven by travelling machineries <input type="checkbox"/> 4 pcs rubber buffers
Travel machinery	<input type="checkbox"/> Frequency converter motor, inverter controller in hoist panel <input type="checkbox"/> Two adjustable speeds with ramp functions min. 5 m/min, max. 20 m/min (MS2-control) <i>Factory settings 20 / 5</i> <input type="checkbox"/> 40 % ED
Electrical outfit	<input type="checkbox"/> Standard 3-phase voltages 50Hz: 220V*, 230V*, 240V*, 380V, 400V, 415V, 500V*, 525V* <input type="checkbox"/> Standard 3-phase voltages 60Hz: 220V*, 230V*, 240V*, 440V, 460V, 480V, 575V*, 600V* <input type="checkbox"/> (*additional price and delivery time) <input type="checkbox"/> Standard control voltages 48V / 50Hz, 115V / 50Hz or 60Hz, 230V / 50Hz or 60Hz <input type="checkbox"/> Assembly according to IEC standards <input type="checkbox"/> IP 55 / NEMA 4 steel control panel <input type="checkbox"/> Electrics for single hoist use in crane application (main contactor or control voltage transformer not included) <input type="checkbox"/> Plug in connectors for power supply and control cables
Environment	<input type="checkbox"/> Ambient temperature -10 °C...+40°C
Surface treatment	<input type="checkbox"/> Epoxy paint. Thickness 100/120 μ (Powder/Wet painting) for load carrying parts
Marking	<input type="checkbox"/> Hoist type plate <input type="checkbox"/> Rope code sticker <input type="checkbox"/> Hoist stickers: brand name and type designation <input type="checkbox"/> Hook stickers: brand name and load
Documents	<input type="checkbox"/> 1 pcs Hoist Owner's Manual <input type="checkbox"/> Hoist test certificate <input type="checkbox"/> Wire rope certificate <input type="checkbox"/> Hook certificate
Delivery	<input type="checkbox"/> Wooden grate packing. Size according to the trolley <input type="checkbox"/> Anticorrosion plastics around the hoist

1.6 SWF code example (SWF: Nova, Factory: Q)

<b>N</b>	<b>B</b>	<b>04</b>	<b>L</b>	<b>5</b>	<b>A</b>	<b>F</b>	<b>P</b>	<b>2</b>	<b>35</b>	<b>A</b>	<b>T</b>	<b>1</b>	<b>N</b>
	(GE09)	DES27	(DES01)	(DIM01)	GE08	HS06	HM01	HM02	(DIM03) (DIM05)	(HS03)	(TM01)	(EL05)	
1	2	3,4	5	6	7	8	9	10	11,12	13	14	15	16

Pos.	Code	Feature code	Feature	Available properties																																				
1	<b>N</b>		Short product name	N Nova hoist																																				
2	<b>B</b>	(GE09)	Frame size	<table border="0"> <tr> <td>B</td> <td>303 mm rope drum diameter</td> <td>A</td> <td>D</td> <td>406 mm rope drum diameter</td> <td>C</td> </tr> <tr> <td>C</td> <td>355 mm rope drum diameter</td> <td>B</td> <td>E</td> <td>608 mm rope drum diameter</td> <td>D</td> </tr> <tr> <td></td> <td></td> <td></td> <td>F</td> <td>608 mm rope drum diameter (2 hoisting motors)</td> <td>E</td> </tr> </table>	B	303 mm rope drum diameter	A	D	406 mm rope drum diameter	C	C	355 mm rope drum diameter	B	E	608 mm rope drum diameter	D				F	608 mm rope drum diameter (2 hoisting motors)	E																		
B	303 mm rope drum diameter	A	D	406 mm rope drum diameter	C																																			
C	355 mm rope drum diameter	B	E	608 mm rope drum diameter	D																																			
			F	608 mm rope drum diameter (2 hoisting motors)	E																																			
3,4	<b>04</b>	DES27	Rope reeving code	<table border="0"> <tr> <td>0</td> <td>1 rope fixed to drum</td> <td>4</td> <td>Number of rope falls per Rope</td> </tr> <tr> <td>1</td> <td>1 rope fixed to drum (in case of 10 rope falls)</td> <td>1</td> <td>1 rope fall</td> </tr> <tr> <td>2</td> <td>2 ropes fixed to drum, true vertical</td> <td>2</td> <td>2 rope falls per rope</td> </tr> <tr> <td>A</td> <td>1 x 6.7 rope on C frame drum</td> <td>4</td> <td>4 rope falls per rope</td> </tr> <tr> <td>B</td> <td>1 x 8 mm rope on D frame drum</td> <td>6</td> <td>6 rope falls per rope</td> </tr> <tr> <td></td> <td></td> <td>8</td> <td>8 rope falls per rope</td> </tr> </table>	0	1 rope fixed to drum	4	Number of rope falls per Rope	1	1 rope fixed to drum (in case of 10 rope falls)	1	1 rope fall	2	2 ropes fixed to drum, true vertical	2	2 rope falls per rope	A	1 x 6.7 rope on C frame drum	4	4 rope falls per rope	B	1 x 8 mm rope on D frame drum	6	6 rope falls per rope			8	8 rope falls per rope	M1 = Machinery hoist, 1 rope fixed to drum, M2 = Machinery hoist, 2 ropes fixed to drum											
0	1 rope fixed to drum	4	Number of rope falls per Rope																																					
1	1 rope fixed to drum (in case of 10 rope falls)	1	1 rope fall																																					
2	2 ropes fixed to drum, true vertical	2	2 rope falls per rope																																					
A	1 x 6.7 rope on C frame drum	4	4 rope falls per rope																																					
B	1 x 8 mm rope on D frame drum	6	6 rope falls per rope																																					
		8	8 rope falls per rope																																					
5	<b>L</b>	(DES01)	Trolley type	<table border="0"> <tr> <td>F</td> <td>Fixed hoist</td> <td>F</td> <td>H</td> <td>Double girder trolley high connection</td> <td>H</td> </tr> <tr> <td>V</td> <td>Machinery hoist</td> <td>V</td> <td>M</td> <td>Double girder trolley medium connection</td> <td>M</td> </tr> <tr> <td>N</td> <td>Normal headroom trolley</td> <td>N</td> <td>W</td> <td>Double girder trolley low connection</td> <td>W</td> </tr> <tr> <td>L</td> <td>Low headroom trolley</td> <td>L</td> <td>A</td> <td>Two hoist trolley, main</td> <td>MA</td> </tr> <tr> <td>J</td> <td>Special low headroom trolley</td> <td>J</td> <td>B</td> <td>Two hoist trolley, aux.</td> <td>MB</td> </tr> <tr> <td>X</td> <td>Special trolley</td> <td>X</td> <td>T</td> <td>Twin hoist (common hook)</td> <td>T</td> </tr> </table>	F	Fixed hoist	F	H	Double girder trolley high connection	H	V	Machinery hoist	V	M	Double girder trolley medium connection	M	N	Normal headroom trolley	N	W	Double girder trolley low connection	W	L	Low headroom trolley	L	A	Two hoist trolley, main	MA	J	Special low headroom trolley	J	B	Two hoist trolley, aux.	MB	X	Special trolley	X	T	Twin hoist (common hook)	T
F	Fixed hoist	F	H	Double girder trolley high connection	H																																			
V	Machinery hoist	V	M	Double girder trolley medium connection	M																																			
N	Normal headroom trolley	N	W	Double girder trolley low connection	W																																			
L	Low headroom trolley	L	A	Two hoist trolley, main	MA																																			
J	Special low headroom trolley	J	B	Two hoist trolley, aux.	MB																																			
X	Special trolley	X	T	Twin hoist (common hook)	T																																			
6	<b>5</b>	(DIM01)	Hoist duty group	<table border="0"> <tr> <td>3</td> <td>ISO M3</td> <td>M3</td> <td>6</td> <td>ISO M6</td> <td>M6</td> </tr> <tr> <td>4</td> <td>ISO M4</td> <td>M4</td> <td>X</td> <td>ISO M4 and load increased (6.3t, 12.5 t etc.)</td> <td></td> </tr> <tr> <td>5</td> <td>ISO M5</td> <td>M5</td> <td></td> <td></td> <td></td> </tr> </table>	3	ISO M3	M3	6	ISO M6	M6	4	ISO M4	M4	X	ISO M4 and load increased (6.3t, 12.5 t etc.)		5	ISO M5	M5																					
3	ISO M3	M3	6	ISO M6	M6																																			
4	ISO M4	M4	X	ISO M4 and load increased (6.3t, 12.5 t etc.)																																				
5	ISO M5	M5																																						
7	<b>A</b>	GE08	Hoist drum length	<table border="0"> <tr> <td>A</td> <td>310 mm rope drum length (if frame size Z, 394 mm)</td> <td>Z</td> <td>1400 mm rope drum length</td> </tr> <tr> <td>B</td> <td>340 mm rope drum length (if frame size Z, 394 mm)</td> <td>J</td> <td>1600 mm rope drum length</td> </tr> <tr> <td>C</td> <td>440 mm rope drum length (if frame size Z, 504 mm)</td> <td>K</td> <td>1900 mm rope drum length</td> </tr> <tr> <td>D</td> <td>540 mm rope drum length</td> <td>L</td> <td>2250 mm rope drum length</td> </tr> <tr> <td>E</td> <td>660 mm rope drum length</td> <td>M</td> <td>2500 mm rope drum length</td> </tr> <tr> <td>F</td> <td>810 mm rope drum length</td> <td>N</td> <td>2800 mm rope drum length</td> </tr> <tr> <td>G</td> <td>1000 mm rope drum length</td> <td>X</td> <td>Special drum length</td> </tr> <tr> <td>H</td> <td>1250 mm rope drum length</td> <td></td> <td></td> </tr> </table>	A	310 mm rope drum length (if frame size Z, 394 mm)	Z	1400 mm rope drum length	B	340 mm rope drum length (if frame size Z, 394 mm)	J	1600 mm rope drum length	C	440 mm rope drum length (if frame size Z, 504 mm)	K	1900 mm rope drum length	D	540 mm rope drum length	L	2250 mm rope drum length	E	660 mm rope drum length	M	2500 mm rope drum length	F	810 mm rope drum length	N	2800 mm rope drum length	G	1000 mm rope drum length	X	Special drum length	H	1250 mm rope drum length						
A	310 mm rope drum length (if frame size Z, 394 mm)	Z	1400 mm rope drum length																																					
B	340 mm rope drum length (if frame size Z, 394 mm)	J	1600 mm rope drum length																																					
C	440 mm rope drum length (if frame size Z, 504 mm)	K	1900 mm rope drum length																																					
D	540 mm rope drum length	L	2250 mm rope drum length																																					
E	660 mm rope drum length	M	2500 mm rope drum length																																					
F	810 mm rope drum length	N	2800 mm rope drum length																																					
G	1000 mm rope drum length	X	Special drum length																																					
H	1250 mm rope drum length																																							
8	<b>F</b>	HS06	Hoisting gear type	<table border="0"> <tr> <td>E</td> <td>Hoist speed 4 m/min</td> <td>H</td> <td>Hoist speed 8 m/min</td> </tr> <tr> <td>F</td> <td>Hoist speed 5 m/min</td> <td>J</td> <td>Hoist speed 10 m/min</td> </tr> <tr> <td>G</td> <td>Hoist speed 6,3 m/min</td> <td></td> <td></td> </tr> </table> <p>Note: Speeds for 4 roped, 50Hz</p>	E	Hoist speed 4 m/min	H	Hoist speed 8 m/min	F	Hoist speed 5 m/min	J	Hoist speed 10 m/min	G	Hoist speed 6,3 m/min																										
E	Hoist speed 4 m/min	H	Hoist speed 8 m/min																																					
F	Hoist speed 5 m/min	J	Hoist speed 10 m/min																																					
G	Hoist speed 6,3 m/min																																							
9	<b>P</b>	HM01	Hoist motor type	<table border="0"> <tr> <td>P</td> <td>Pole change motor</td> <td>E</td> <td>Ex-proof pole change motor</td> </tr> <tr> <td>T</td> <td>Frequency converter motor</td> <td>O</td> <td>Single speed motor</td> </tr> <tr> <td>R</td> <td>Pole change motor 3:1</td> <td>C</td> <td>Cast iron pole change motor</td> </tr> </table>	P	Pole change motor	E	Ex-proof pole change motor	T	Frequency converter motor	O	Single speed motor	R	Pole change motor 3:1	C	Cast iron pole change motor																								
P	Pole change motor	E	Ex-proof pole change motor																																					
T	Frequency converter motor	O	Single speed motor																																					
R	Pole change motor 3:1	C	Cast iron pole change motor																																					
10	<b>2</b>	HM02	Hoisting motor size	# 1-9 as motor power code (A, Z, X) (see technical guide)																																				
11,12	<b>35</b>	(DIM03) (DIM05)	Flange width/ Rail gauge	# Flange width (L / N trolleys) i.e. 350 mm = 35 # Rail gauge (D trolleys) i.e. 1200 mm = 12																																				
13	<b>A</b>	(HS03)	Overload device	<table border="0"> <tr> <td>A</td> <td>Mechanical limit switch</td> <td>MEC</td> <td>C</td> <td>Hoist power measurement</td> <td>POW</td> </tr> <tr> <td>B</td> <td>Strain gauge</td> <td>SG</td> <td>D</td> <td>Mechanical limit switch and hoist power measure</td> <td>MECPOW</td> </tr> <tr> <td>N</td> <td>No overload device</td> <td>NO</td> <td></td> <td></td> <td></td> </tr> </table>	A	Mechanical limit switch	MEC	C	Hoist power measurement	POW	B	Strain gauge	SG	D	Mechanical limit switch and hoist power measure	MECPOW	N	No overload device	NO																					
A	Mechanical limit switch	MEC	C	Hoist power measurement	POW																																			
B	Strain gauge	SG	D	Mechanical limit switch and hoist power measure	MECPOW																																			
N	No overload device	NO																																						
14	<b>T</b>	(TM01)	Trolley motor type	<table border="0"> <tr> <td>N</td> <td>No trolley motor controls</td> <td>O</td> <td>Single speed motor</td> <td>O</td> </tr> <tr> <td>P</td> <td>Pole change motor</td> <td>P</td> <td>Frequency converter motor</td> <td>T</td> </tr> <tr> <td>E</td> <td>Ex-proof pole change motor</td> <td>E</td> <td>Steel frame motor</td> <td>C</td> </tr> </table>	N	No trolley motor controls	O	Single speed motor	O	P	Pole change motor	P	Frequency converter motor	T	E	Ex-proof pole change motor	E	Steel frame motor	C																					
N	No trolley motor controls	O	Single speed motor	O																																				
P	Pole change motor	P	Frequency converter motor	T																																				
E	Ex-proof pole change motor	E	Steel frame motor	C																																				
15	<b>1</b>	(EL05)	Electric provisions	<table border="0"> <tr> <td>1</td> <td>Single hoist for crane</td> <td>CRANE</td> <td>5</td> <td>Only condition monitoring unit</td> <td>ECM</td> </tr> <tr> <td>2</td> <td>Hoist for tandem use</td> <td>TANDEM</td> <td>6</td> <td>Hoist with universal bridge panel</td> <td>UNV</td> </tr> <tr> <td>3</td> <td>Solo hoist</td> <td>SOLO</td> <td>7</td> <td>Twin hoist use</td> <td>TWIN</td> </tr> <tr> <td>4</td> <td>Hoist without electric controls</td> <td>NO</td> <td>8</td> <td>Hoist with all crane electrics</td> <td>ALL</td> </tr> </table>	1	Single hoist for crane	CRANE	5	Only condition monitoring unit	ECM	2	Hoist for tandem use	TANDEM	6	Hoist with universal bridge panel	UNV	3	Solo hoist	SOLO	7	Twin hoist use	TWIN	4	Hoist without electric controls	NO	8	Hoist with all crane electrics	ALL												
1	Single hoist for crane	CRANE	5	Only condition monitoring unit	ECM																																			
2	Hoist for tandem use	TANDEM	6	Hoist with universal bridge panel	UNV																																			
3	Solo hoist	SOLO	7	Twin hoist use	TWIN																																			
4	Hoist without electric controls	NO	8	Hoist with all crane electrics	ALL																																			
16	<b>N</b>		Special properties	N Standard hoist without any options F Options selected only from feature list S Special properties																																				

## 2 TECHNICAL CHARACTERISTICS

Load (kg)	Frame	Falls	Trolley							Duty		Drum		Rope		*Drum	Contactor control				Inverter control						
			D	D	D					FEM	ISO	Code	HOL	Load	Type		Gear		Motor	Speed	(tm/min)	Gear		Motor	Speed	(tm/min)	
			L	H	M	W	N	F	V				(m)	(kg)			Type	Ratio		(m/min)		Type	Ratio		(m/min)		
400	B	M1								V	3m	M6	A	24	400	B	*	F	134.2	P 1	20/3.3	8	F	134.2	T 1	20	8
			C	38	G	106	P 2	25/4.2	10				G	106				T 2	25	10							
					H	87.7	P 3	32/5.3	12.8				H	87.7				T 3	32	12.8							
400	B	M2								V	3m	M6	A	7	400	B	*	F	134.2	P 1	20/3.3	8	F	134.2	T 1	20	8
			C	15	G	106	P 2	25/4.2	10				G	106				T 2	25	10							
					H	87.7	P 3	32/5.3	12.8				H	87.7				T 3	32	12.8							
500	B	M1								V	2m	M5	A	24	500	B	*	F	134.2	P 1	20/3.3	10	F	134.2	T 1	20	10
			C	38	G	106	P 2	25/4.2	12.5				G	106				T 2	25	12.5							
					H	87.7	P 3	32/5.3	16				H	87.7				T 3	32	16							
500	B	M2								V	2m	M5	A	7	500	B	*	F	134.2	P 1	20/3.3	10	F	134.2	T 1	20	10
			C	15	G	106	P 2	25/4.2	12.5				G	106				T 2	25	12.5							
					H	87.7	P 3	32/5.3	16				H	87.7				T 3	32	16							
500	B	02	L	H	M		N	F	3m	M6	A	12	250	A	*	F	134.2	P 1	10/1.7	5	F	134.2	T 1	10	5		
								C			19	G				106	P 2	12.5/2.1	6.3		G	106	T 2	12.5		6.3	
								H			87.7	P 3				16/2.7	8	H	87.7		T 3	16	8				
	C	A2	L						C	22.5	B	F	160.3	P 2	10/1.7	5	F	160.3	T 2	10	5						
									D	30		H	104.7	P 4	16/2.7	8	H	104.7	T 4	16		8					
630	B	02	L	H	M		N	F	3m	M6	A	12	315	A	*	F	134.2	P 1	10/1.7	6.3	F	134.2	T 1	10	6.3		
								C			19	G				106	P 2	12.5/2.1	8		G	106	T 2	12.5		8	
								H			87.7	P 3				16/2.7	10	H	87.7		T 3	16	10				
	C	A2	L						C	22.5	B	F	160.3	P 2	10/1.7	6.3	F	160.3	T 2	10	6.3						
									D	30		H	104.7	P 4	16/2.7	10	H	104.7	T 4	16		10					
600	B	M1								V	3m	M6	A	24	600	B	*	F	134.2	P 2	20/3.3	12	F	134.2	T 2	20	12
			C	38	G	106	P 2	25/4.2	15				G	106				T 2	25	15							
					H	87.7	P 3	32/5.3	19.2				H	87.7				T 3	32	19.2							
600	B	M2								V	3m	M6	A	7	600	B	*	F	134.2	P 2	20/3.3	12	F	134.2	T 2	20	12
			C	15	G	106	P 2	25/4.2	15				G	106				T 2	25	15							
					H	87.7	P 3	32/5.3	19.2				H	87.7				T 3	32	19.2							
800	B	M1								V	2m	M5	A	24	800	B	*	F	134.2	P 2	20/3.3	16	F	134.2	T 2	20	16
			C	22.5	B	F	160.3	P 2	10/1.7				8	F				160.3	T 2	10	8						

Load (kg)	Frame	Falls	Trolley						Duty		Drum		Rope		*)Drum	Contactor control				Inverter control							
			D	D	D				FEM	ISO	Code	HOL	Load	Type		Gear		Motor	Speed	(tm/min)	Gear		Motor	Speed	(tm/min)		
			L	H	M	W	N	F	V				(m)	(kg)			Type	Ratio		(m/min)		Type	Ratio		(m/min)		
											D	30				H	104.7	P	4	16/2.7	12.8	H	104.7	T	4	16	12.8
1000	Z	02	J						2m	M5	B	6	500	N	E	133.8	P	X	8/1.3	8							
								B			12	E		133.8	O	X	8	8									
	B	02	L	H	M		N	F			A	12	A	F	134.2	P	1	10/1.7	10	F	134.2	T	1	10	10		
											C	19		G	106	P	2	12.5/2.1	12.5	G	106	T	2	12.5	12.5		
														H	87.7	P	3	16/2.7	16	H	87.7	T	3	16	16		
											C	22.5	B	F	160.3	P	2	10/1.7	10	F	160.3	T	2	10	10		
											D	30		H	104.7	P	4	16/2.7	16	H	104.7	T	4	16	16		
1000	B	04	L	H	M		N	F	3m	M6	A	6	250	A	F	134.2	P	1	5/0.8	5	F	134.2	T	1	5	5	
								C			9.5	G		106	P	2	6.3/1.1	6.3	G	106	T	2	6.3	6.3	6.3	6.3	
														H	87.7	P	3	8/1.3	8	H	87.7	T	3	8	8		
	C	A4	L								C	11	A	F	160.3	P	2	5/0.8	5	F	160.3	T	2	5	5		
										D	15		H	104.7	P	4	8/1.3	8	H	104.7	T	4	8	8			
1000	B	02	L	H	M		N	F	3m	M6	A	12	500	A	F	134.2	P	2	10/1.7	10	F	134.2	T	2	10	10	
								C			19	G		106	P	2	12.5/2.1	12.5	G	106	T	2	12.5	12.5	12.5		
														H	87.7	P	3	16/2.7	16	H	87.7	T	3	16	16		
	C	A2	L								C	22.5	B	F	160.3	P	2	10/1.7	10	F	160.3	T	2	10	10		
										D	30		H	104.7	P	4	16/2.7	16	H	104.7	T	4	16	16			
1250	B	04	L	H	M		N	F	3m	M6	A	6	313	A	F	134.2	P	1	5/0.8	6.3	F	134.2	T	1	5	6.3	
								C			9.5	G		106	P	2	6.3/1.1	8	G	106	T	2	6.3	8	8		
														H	87.7	P	3	8/1.3	10	H	87.7	T	3	8	10		
	C	A4	L								C	11	A	F	160.3	P	2	5/0.8	6.3	F	160.3	T	2	5	6.3		
										D	15		H	104.7	P	4	8/1.3	10	H	104.7	T	4	8	10			
1250	B	02	L	H	M		N	F	3m	M6	A	12	625	A	F	134.2	P	2	10/1.7	12.5	F	134.2	T	2	10	12.5	
								C			19	G		106	P	2	12.5/2.1	16	G	106	T	2	12.5	16	16		
														H	87.7	P	3	16/2.7	20	H	87.7	T	3	16	20		
	C	A2	L								C	22.5	B	F	160.3	P	2	10/1.7	12.5	F	160.3	T	2	10	12.5		
										D	30		H	104.7	P	4	16/2.7	20	H	104.7	T	4	16	20			
1600	B	02	L	H	M		N	F	2m	M5	A	12	800	A	F	134.2	P	2	10/1.7	16	F	134.2	T	2	10	16	
								C			19	G		106	P	2	12.5/2.1	20	G	106	T	2	12.5	20	20		
														H	87.7	P	3	16/2.7	25.6	H	87.7	T	3	16	25.6		
	C	A2	L								C	22.5	B	F	160.3	P	2	10/1.7	16	F	160.3	T	2	10	16		
										D	30		H	104.7	P	4	16/2.7	26	H	104.7	T	4	16	26			

Load (kg)	Frame	Falls	Trolley							Duty		Drum		Rope		*Drum	Contactor control				Inverter control					
			D	D	D					FEM	ISO	Code	HOL	Load	Type		Gear		Motor	Speed	(tm/min)	Gear		Motor	Speed	(tm/min)
			L	H	M	W	N	F	V				(m)	(kg)			Type	Ratio		(m/min)		Type	Ratio		(m/min)	
1600	B	04	L	H	M	N	F	3m	M6	A	6	400	A	F	134.2	P 1	5/0.8	8	F	134.2	T 1	5	8			
										C	9.5			G	106	P 2	6.3/1.1	10	G	106	T 2	6.3	10			
														H	87.7	P 3	8/1.3	12.8	H	87.7	T 3	8	12.8			
	C	A4	L								C	11		A	F	160.3	P 2	5/0.8	8	F	160.3	T 2	5	8		
													D	15			H	104.7	P 4	8/1.3	12.8	H	104.7	T 4	8	12.8
2000	Z	04	J	L	H	M	N	2m	M5	B	6	500	N	E	133.8	P X	4/0.7	8								
										C	9			G	79.1	O Z	6.7	13.4								
	B	04	L	H	M	N	F	2m	M5	A	6		A	F	134.2	P 1	5/0.8	10	F	134.2	T 1	5	10			
										C	9.5			G	106	P 2	6.3/1.1	12.6	G	106	T 2	6.3	12.6			
														H	87.7	P 3	8/1.3	16	H	87.7	T 3	8	16			
C	A4	L								C	11		A	F	160.3	P 2	5/0.8	10	F	160.3	T 2	5	10			
												D	15			H	104.7	P 4	8/1.3	16	H	104.7	T 4	8	16	
2000	B	04	L	H	M	N	F	3m	M6	A	6	500	A	F	134.2	P 2	5/0.8	10	F	134.2	T 2	5	10			
										C	9.5			G	106	P 2	6.3/1.1	12.6	G	106	T 2	6.3	12.6			
														H	87.7	P 3	8/1.3	16	H	87.7	T 3	8	16			
	C	A4	L								C	11		A	F	160.3	P 2	5/0.8	10	F	160.3	T 2	5	10		
													D	15			H	104.7	P 4	8/1.3	16	H	104.7	T 4	8	16
2500	B	04	L	H	M	N	F	3m	M6	A	6	625	A	F	134.2	P 2	5/0.8	12.5	F	134.2	T 2	5	12.5			
										C	9.5			G	106	P 2	6.3/1.1	16	G	106	T 2	6.3	16			
														H	87.7	P 3	8/1.3	20	H	87.7	T 3	8	20			
	C	A4	L								C	11		A	F	160.3	P 2	5/0.8	12.5	F	160.3	T 2	5	12.5		
													D	15			H	104.7	P 4	8/1.3	20	H	104.7	T 4	8	20
3200	B	04	L	H	M	N	F	2m	M5	A	6	800	A	F	134.2	P 2	5/0.8	16	F	134.2	T 2	5	16			
										C	9.5			G	106	P 2	6.3/1.1	20	G	106	T 2	6.3	20			
														H	87.7	P 3	8/1.3	25.6	H	87.7	T 3	8	25.6			
	C	A4	L								C	11		A	F	160.3	P 2	5/0.8	16	F	160.3	T 2	5	16		
													D	15			H	104.7	P 4	8/1.3	25.6	H	104.7	T 4	8	25.6
1000	C	M1						3m	M6	B	24	1000	F	*	F	160.3	P 3	20/3.3	20	F	160.3	T 3	20	20		
										C	36			H	104.7	P 4	32/5.3	32	H	104.7	T 4	32	32			
										D	48															
										E	62															
1000	C	M2						3m	M6	B	9.5	1000	B	*	F	160.3	P 3	20/3.3	20	F	160.3	T 3	20	20		

Load (kg)	Frame	Falls	Trolley						Duty		Drum		Rope		*)Drum	Contactor control				Inverter control							
			D	D	D				FEM	ISO	Code	HOL	Load	Type		Gear		Motor	Speed	(tm/min)	Gear		Motor	Speed	(tm/min)		
			L	H	M	W	N	F	V				(m)	(kg)			Type	Ratio		(m/min)		Type	Ratio		(m/min)		
											C	17				H	104.7	P	4	32/5.3	32	H	104.7	T	4	32	32
											D	25															
											E	34															
1250	C	M1						V	2m	M5	B	24	1250	F	*	F	160.3	P	3	20/3.3	25	F	160.3	T	3	20	25
											C	36				H	104.7	P	4	32/5.3	40	H	104.7	T	4	32	40
											D	48															
											E	62															
1250	C	M2						V	2m	M5	B	9.5	1250	B	*	F	160.3	P	3	20/3.3	25	F	160.3	T	3	20	25
											C	17				H	104.7	P	4	32/5.3	40	H	104.7	T	4	32	40
											D	25															
											E	34															
1600	C	M1						V	1Am	M4	B	24	1600	Y	*	E	192.6	P	3	16/2.7	26	E	192.6	T	3	16	26
											C	36															
											D	48															
											E	62															
1600	C	M2						V	1Am	M4	B	9.5	1600	B	*	E	192.6	P	3	16/2.7	26	E	192.6	T	3	16	26
											C	17															
											D	25															
											E	34															
1600	C	02	L	H	M		N	F	3m	M6	B	12	800	D		F	160.3	P	2	10/1.7	16	F	160.3	T	2	10	16
											C	18				H	104.7	P	4	16/2.7	26	H	104.7	T	4	16	26
											D	24		F													
			H	M		N	F				E	30		F													
2000	C	02	L	H	M		N	F	3m	M6	B	12	1000	D		F	160.3	P	3	10/1.7	20	F	160.3	T	3	10	20
											C	18				H	104.7	P	4	16/2.7	32	H	104.7	T	4	16	32
											D	24		F													
			H	M		N	F				E	30		F													
2500	C	02	L	H	M		N	F	2m	M5	B	12	1250	D		F	160.3	P	3	10/1.7	25	F	160.3	T	3	10	25
											C	18				H	104.7	P	4	16/2.7	40	H	104.7	T	4	16	40
											D	24		F													
			H	M		N	F				E	30		F													
3200	C	04	L	H	M		N	F	3m	M6	B	6	800	D		F	160.3	P	2	5/0.8	16	F	160.3	T	2	5	16
											C	9				H	104.7	P	4	8/1.3	26	H	104.7	T	4	8	26

Load (kg)	Frame	Falls	Trolley							Duty		Drum		Rope		*Drum	Contactor control				Inverter control						
			D	D	D					FEM	ISO	Code	HOL	Load	Type		Gear		Motor	Speed	(tm/min)	Gear		Motor	Speed	(tm/min)	
			L	H	M	W	N	F	V				(m)	(kg)			Type	Ratio		(m/min)		Type	Ratio		(m/min)		
											D	12															
											E	15															
3200	C	02	L	H	M				1Am	M4	B	12	1600	D	E	192.6	P	3	8/1.3	26	E	192.6	T	3	8	26	
											C	18															
											D	24		Y													
											E	30		Y													
4000	C	04	L	H	M				3m	M6	B	6	1000	D	F	160.3	P	3	5/0.8	20	F	160.3	T	3	5	20	
											C	9			H	104.7	P	4	8/1.3	32	H	104.7	T	4	8	32	
											D	12															
											E	15															
5000	C	04	L	H	M				2m	M5	B	6	1250	D	F	160.3	P	3	5/0.8	25	F	160.3	T	3	5	25	
											C	9			H	104.7	P	4	8/1.3	40	H	104.7	T	4	8	40	
											D	12															
											E	15															
6300	C	04	L	H	M			F	1Am	M4	B	6	1575	D	E	192.6	P	3	4/0.7	25	E	192.6	T	3	4	25	
											C	9															
											D	12															
											E	15															
6000	C	06		H	M			N F	3m	M6	C	6	1000	E	F	160.3	P	3	3.2/0.5	24	F	160.3	T	3	3.2	24	
											D	8			H	104.7	P	4	5/0.8	38	H	104.7	T	4	5	38	
											E	10															
7500	C	06		H	M			N F	2m	M5	C	6	1250	E	F	160.3	P	3	3.2/0.5	24	F	160.3	T	3	3.2	24	
											D	8			H	104.7	P	4	5/0.8	38	H	104.7	T	4	5	38	
											E	10															
8000	C	08		H	M			N F	2m	M5	C	4.5	1000	E	F	160.3	P	3	2.5/0.4	20	F	160.3	T	3	2.5	20	
											D	6			H	104.7	P	4	4/0.7	32	H	104.7	T	4	4	32	
											E	7.5															
10000	C	08		H	M			N F	1Am	M4	C	4.5	1250	E	F	160.3	P	3	2.5/0.4	25	F	160.3	T	3	2.5	25	
											D	6			H	104.7	P	4	4/0.7	40	H	104.7	T	4	4	40	
											E	7.5															
2000	D	M1						V	3m	M6	D	36	2000	J	*	F	185.3	P	5	20/3.3	40	F	185.3	T	5	20	40
											E	48				H	113.8	P	6	32/5.3	64	H	113.8	T	6	32	64
											F	64				J	94.3	P	7	40/6.7	80	J	94.3	T	7	40	80

Load (kg)	Frame	Falls	Trolley						Duty		Drum		Rope		*)Drum	Contactor control				Inverter control						
			D	D	D				FEM	ISO	Code	HOL	Load	Type		Gear		Motor	Speed	(tm/min)	Gear		Motor	Speed	(tm/min)	
			L	H	M	W	N	F	V				(m)	(kg)			Type	Ratio		(m/min)		Type	Ratio		(m/min)	
											G	82														
2000	D	M2					V	3m	M6	D	18	2000	F	*	F	185.3	P	5	20/3.3	40	F	185.3	T	5	20	40
										E	27			H	113.8	P	6	32/5.3	64	H	113.8	T	6	32	64	
										F	38			J	94.3	P	7	40/6.7	80	J	94.3	T	7	40	80	
										G	50															
2500	D	M1					V	2m	M5	D	36	2500	J	*	F	185.3	P	5	20/3.3	50	F	185.3	T	5	20	50
										E	48			H	113.8	P	6	32/5.3	80	H	113.8	T	6	32	80	
										F	64			J	94.3	P	7	40/6.7	100	J	94.3	T	7	40	100	
										G	82															
2500	D	M2					V	2m	M5	D	18	2500	F	*	F	185.3	P	5	20/3.3	50	F	185.3	T	5	20	50
										E	27			H	113.8	P	6	32/5.3	80	H	113.8	T	6	32	80	
										F	38			J	94.3	P	7	40/6.7	100	J	94.3	T	7	40	100	
										G	50															
3150	D	M1					V	1Am	M4	D	36	3150	Z	*	E	223.8	P	5	16/2.7	50	E	223.8	T	5	16	50
										E	48															
										F	64															
										G	82															
3150	D	M2					V	1Am	M4	D	18	3150	Y	*	E	223.8	P	5	16/2.7	50	E	223.8	T	5	16	50
										E	27															
										F	38															
										G	50															
4000	D	02	L	H	M	W	N	F	3m	M6	D	18	2000	G	F	185.3	P	5	10/1.7	40	F	185.3	T	5	10	40
											E	24			H	113.8	P	6	16/2.7	64	H	113.8	T	6	16	64
											F	32	J	J	94.3	P	7	20/3.3	80	J	94.3	T	7	20	80	
											G	40	J													
5000	D	02	L	H	M	W	N	F	2m	M5	D	18	2500	G	F	185.3	P	5	10/1.7	50	F	185.3	T	5	10	50
											E	24			H	113.8	P	6	16/2.7	80	H	113.8	T	6	16	80
											F	32	J	J	94.3	P	7	20/3.3	100	J	94.3	T	7	20	100	
											G	40	J													
6300	D	02	L	H	M	W	N	F	1Am	M4	D	18	3100	G	E	223.8	P	5	8/1.3	50	E	223.8	T	5	8	50
											E	24														
											F	32	Z													
											G	40	Z													

Load (kg)	Frame	Falls	Trolley							Duty		Drum		Rope		*Drum	Contactor control				Inverter control									
			D	D	D					FEM	ISO	Code	HOL	Load	Type		Gear		Motor	Speed	(tm/min)	Gear		Motor	Speed	(tm/min)				
			L	H	M	W	N	F	V				(m)	(kg)			Type	Ratio		(m/min)		Type	Ratio		(m/min)					
6300	D	04	L	H	M	W	N	F	3m	M6	D	9	1600	G	F	185.3	P 5	5/0.8	38	F	185.3	T 5	5	38						
			E	12			H	113.8			P 6	8/1.3	50	H	113.8	T 6	8	50												
			F	16			J	94.3			P 7	10	63	J	94.3	T 7	10	63												
			G	20																										
			H	M	W	N	F																							
8000	D	04	L	H	M	W	N	F	3m	M6	D	9	2000	G	F	185.3	P 5	5/0.8	40	F	185.3	T 5	5	40						
			E	12			H	113.8			P 6	8/1.3	64	H	113.8	T 6	8	64												
			F	16			J	94.3			P 7	10	80	J	94.3	T 7	10	80												
			G	20																										
			H	M	W	N	F																							
10000	D	04	L	H	M	W	N	F	2m	M5	D	9	2500	G	F	185.3	P 5	5/0.8	50	F	185.3	T 5	5	50						
			E	12			H	113.8			P 6	8/1.3	80	H	113.8	T 6	8	80												
			F	16			J	94.3			P 7	10	100	J	94.3	T 7	10	100												
			G	20																										
			H	M	W	N	F																							
12500	D	04	L	H	M	W		F	1Am	M4	D	9	3125	G	E	223.8	P 5	4/0.7	50	E	223.8	T 5	4	50						
			E	12																										
			F	16																										
			G	20																										
			H	M	W		F																							
12000	D	06	H					M	W	N	F	3m	M6	D	6	2000	H	F	185.3	P 5	3.2/0.5	48	F	185.3	T 5	3.2	48			
			E	8			H	113.8	P 6	5/0.8	75			H	113.8	T 6	5	75												
			F	10			J	94.3	P 7	6.3/1.1	95			J	94.3	T 7	6.3	95												
			G	13																										
			H					M	W	N	F																			
15000	D	06	H					M	W	N	F	2m	M5	D	6	2500	H	F	185.3	P 5	3.2/0.5	48	F	185.3	T 5	3.2	48			
			E	8			H	113.8	P 6	5/0.8	75			H	113.8	T 6	5	75												
			F	10			J	94.3	P 7	6.3/1.1	95			J	94.3	T 7	6.3	95												
			G	13																										
			H					M	W	N	F																			
16000	D	08	H					M	W	N	F	2m	M5	D	4.5	2000	H	F	185.3	P 5	2.5/0.4	40	F	185.3	T 5	2.5	40			
			E	6			H	113.8	P 6	4/0.7	64			H	113.8	T 6	4	64												
			F	8			J	94.3	P 7	5/0.8	80			J	94.3	T 7	5	80												
			G	10																										
			H					M	W	N	F																			
20000	D	08	H					M	W	N	F	1Am	M4	D	4.5	2500	H	F	185.3	P 5	2.5/0.4	50	F	185.3	T 5	2.5	50			
			E	6			H	113.8	P 6	4/0.7	80			H	113.8	T 6	4	80												
			F	8			J	94.3	P 7	5/0.8	100			J	94.3	T 7	5	100												
			G	10																										
			H					M	W	N	F																			

Load (kg)	Frame	Falls	Trolley						Duty		Drum		Rope		*)Drum	Contactor control				Inverter control							
			D	D	D				FEM	ISO	Code	HOL	Load	Type		Gear		Motor	Speed	(tm/min)	Gear		Motor	Speed	(tm/min)		
			L	H	M	W	N	F	V				(m)	(kg)			Type	Ratio		(m/min)		Type	Ratio		(m/min)		
4000	D	22	H	M	W	N	F	3m	M6	D	8.5	1000	D	F	185.3	P	5	10/1.7	40	F	185.3	T	5	10	40		
										E	13	2000	+	H	113.8	P	6	16/2.7	64	H	113.8	T	6	16	64		
										F	18		Dr	J	94.3	P	7	20/3.3	80	J	94.3	T	7	20	80		
										G	25																
										H	33.5																
										J	46																
5000	D	22	H	M	W	N	F	2m	M5	D	8.5	1250	D	F	185.3	P	5	10/1.7	50	F	185.3	T	5	10	50		
										E	13	2500	+	H	113.8	P	6	16/2.7	80	H	113.8	T	6	16	80		
										F	18		Dr	J	94.3	P	7	20/3.3	100	J	94.3	T	7	20	100		
										G	25																
										H	33.5																
										J	46																
6300	D	24	H	M	W	N	F	3m	M6	D	4	800	D	F	185.3	P	5	5/0.8	32	F	185.3	T	5	5	32		
										E	6.5	1600	+	H	113.8	P	6	8/1.3	50	H	113.8	T	6	8	50		
										F	9		Dr	J	94.3	P	7	10/1.7	63	J	94.3	T	7	10	63		
										G	12.5																
										H	16.5																
										J	23																
8000	D	24	H	M	W	N	F	3m	M6	D	4	1000	D	F	185.3	P	5	5/0.8	40	F	185.3	T	5	5	40		
										E	6.5	2000	+	H	113.8	P	6	8/1.3	64	H	113.8	T	6	8	64		
										F	9		Dr	J	94.3	P	7	10/1.7	80	J	94.3	T	7	10	80		
										G	12.5																
										H	16.5																
										J	23																
10000	D	24	H	M	W	N	F	2m	M5	D	4	1250	D	F	185.3	P	5	5/0.8	50	F	185.3	T	5	5	50		
										E	6.5	2500	+	H	113.8	P	6	8/1.3	80	H	113.8	T	6	8	80		
										F	9		Dr	J	94.3	P	7	10/1.7	100	J	94.3	T	7	10	100		
										G	12.5																
										H	16.5																
										J	23																
12000	D	26	H	M	W	N	F	3m	M6	E	4	1000	E	F	185.3	P	5	3.2/0.5	38	F	185.3	T	5	3.2	38		
										F	6	2000	+	H	113.8	P	6	5/0.8	60	H	113.8	T	6	5	60		
										G	8		Er	J	94.3	P	7	6.3/1.1	76	J	94.3	T	7	6.3	76		

Load (kg)	Frame	Falls	Trolley							Duty		Drum		Rope		*)Drum	Contactor control				Inverter control						
			D	D	D					FEM	ISO	Code	HOL	Load	Type		Gear		Motor	Speed	(tm/min)	Gear		Motor	Speed	(tm/min)	
			L	H	M	W	N	F	V				(m)	(kg)			Type	Ratio		(m/min)		Type	Ratio		(m/min)		
											H	11															
											J	15															
15000	D	26	H	M	W	N	F		2m	M5	E	4	1250	E	F	185.3	P	5	3.2/0.5	48	F	185.3	T	5	3.2	48	
											F	6	2500	+	H	113.8	P	6	5/0.8	75	H	113.8	T	6	5	75	
											G	8		Er	J	94.3	P	7	6.3/1.1	95	J	94.3	T	7	6.3	95	
											H	11															
											J	15															
16000	D	28	H	M	W	N	F		2m	M5	F	4.5	1000	E	F	185.3	P	5	2.5/0.4	40	F	185.3	T	5	2.5	40	
											G	6	2000	+	H	113.8	P	6	4/0.7	64	H	113.8	T	6	4	64	
											H	8		Er	J	94.3	P	7	5/0.8	80	J	94.3	T	7	5	80	
											J	11.5															
20000	D	28	H	M	W	N	F		1Am	M4	F	4.5	1250	E	F	185.3	P	5	2.5/0.4	50	F	185.3	T	5	2.5	50	
											G	6	2500	+	H	113.8	P	6	4/0.7	80	H	113.8	T	6	4	80	
											H	8		Er	J	94.3	P	7	5/0.8	100	J	94.3	T	7	5	100	
											J	11.5															
3200	E	M1						V	3m	M6	C	32	3200	M	*	E	344.9	P	6	16/2.7	51	E	344.9	T	6	16	51
											D	43				F	269.1	P	6	20/3.3	64	F	269.1	T	6	20	64
											E	56.5				G	223.1	P	7	25/4	80	G	223.1	T	7	25	80
											F	73									H	184.1	T	8	32	102	
											G	94.5									J	143.6	T	9	40	128	
											H	122.5															
											J	161.5															
											K	195															
3200	E	M2						V	3m	M6	E	37	3200	J	*	E	344.9	P	6	16/2.7	51	E	344.9	T	6	16	51
											F	48.5				F	269.1	P	6	20/3.3	64	F	269.1	T	6	20	64
											G	63				G	223.1	P	7	25/4	80	G	223.1	T	7	25	80
											H	82									H	184.1	T	8	32	102	
											J	108.5									J	143.6	T	9	40	128	
											K	131.5															
											L	158.5															
											M	177.5															
											N	200.5															

Load (kg)	Frame	Falls	Trolley						Duty		Drum		Rope		*)Drum	Contactor control				Inverter control								
			D	D	D				FEM	ISO	Code	HOL	Load	Type		Gear		Motor	Speed	(tm/min)	Gear		Motor	Speed	(tm/min)			
			L	H	M	W	N	F	V				(m)	(kg)			Type	Ratio		(m/min)		Type	Ratio		(m/min)			
4000	E	M1						V	2m	M5	C	32	4000	M	*	E	344.9	P	6	16/2.7	64	E	344.9	T	6	16	64	
											D	43			F	269.1	P	6	20/3.3	80	F	269.1	T	6	20	80		
											E	56.5			G	223.1	P	7	25/4	100	G	223.1	T	7	25	100		
											F	73									H	184.1	T	8	32	128		
											G	94.5									J	143.6	T	9	40	160		
											H	122.5																
											J	161.5																
4000	E	M2						V	2m	M5	E	37	4000	J	*	E	344.9	P	6	16/2.7	64	E	344.9	T	6	16	64	
											F	48.5			F	269.1	P	6	20/3.3	80	F	269.1	T	6	20	80		
											G	63			G	223.1	P	7	25/4	100	G	223.1	T	7	25	100		
											H	82									H	184.1	T	8	32	128		
											J	108.5									J	143.6	T	9	40	160		
											K	131.5																
											L	158.5																
5000	E	M1						V	1Am	M4	C	32	5000	M	*	E	344.9	P	6	16/2.7	80	E	344.9	T	6	16	80	
											D	43			F	269.1	P	7	20/3.3	100	F	269.1	T	7	20	100		
											E	56.5			G	223.1	P	8	25/4	125	G	223.1	T	8	25	125		
											F	73									H	184.1	T	9	32	160		
											G	94.5									J	143.6	T	A	40	200		
											H	122.5																
											J	161.5																
5000	E	M2						V	1Am	M4	E	37	5000	J	*	E	344.9	P	6	16/2.7	80	E	344.9	T	6	16	80	
											F	48.5			F	269.1	P	7	20/3.3	100	F	269.1	T	7	20	100		
											G	63			G	223.1	P	8	25/4	125	G	223.1	T	8	25	125		
											H	82									H	184.1	T	9	32	160		
											J	108.5									J	143.6	T	A	40	200		
											K	131.5																
											L	158.5																

Load (kg)	Frame	Falls	Trolley							Duty		Drum		Rope		*Drum	Contactor control				Inverter control					
			D	D	D					FEM	ISO	Code	HOL	Load	Type		Gear		Motor	Speed	(tm/min)	Gear		Motor	Speed	(tm/min)
			L	H	M	W	N	F	V				(m)	(kg)			Type	Ratio		(m/min)		Type	Ratio		(m/min)	
											N	200.5														
6300	E	02	M	N	F	3m	M6	C	15.5	3150	K	E	344.9	P	6	8/1.3	50	E	344.9	T	6	8	50			
								D	21			F	269.1	P	6	10/1.7	63	F	269.1	T	6	10	63			
								E	28		M	G	223.1	P	7	12.5/2.1	79	G	223.1	T	7	12.5	79			
								F	36		M							H	184.1	T	8	16	101			
								G	47		M							J	143.6	T	9	20	126			
								H	61		M															
								J	80.5		M															
8000	E	02	M	N	F	2m	M5	C	15.5	4000	K	E	344.9	P	6	8/1.3	64	E	344.9	T	6	8	64			
								D	21			F	269.1	P	6	10/1.7	80	F	269.1	T	6	10	80			
								E	28		M	G	223.1	P	7	12.5/2.1	100	G	223.1	T	7	12.5	100			
								F	36		M							H	184.1	T	8	16	128			
								G	47		M							J	143.6	T	9	20	160			
								H	61		M															
								J	80.5		M															
10000	E	02	M	N	F	1Am	M4	C	15.5	5000	K	E	344.9	P	6	8/1.3	80	E	344.9	T	6	8	80			
								D	21			F	269.1	P	7	10/1.7	100	F	269.1	T	7	10	100			
								E	28		M	G	223.1	P	8	12.5/2.1	125	G	223.1	T	8	12.5	125			
								F	36		M							H	184.1	T	9	16	160			
								G	47		M							J	143.6	T	A	20	200			
								H	61		M															
								J	80.5		M															
12500	E	04	M	N	F	3m	M6	C	7.5	3125	K	E	344.9	P	6	4/0.7	50	E	344.9	T	6	4	50			
								D	10.5			F	269.1	P	6	5/0.8	63	F	269.1	T	6	5	63			
								E	14			G	223.1	P	7	6.3/1.1	79	G	223.1	T	7	6.3	79			
								F	18									H	184.1	T	8	8	100			
								G	23.5									J	143.6	T	9	10	125			
								H	30.5																	
								J	40																	
								K	48.5																	

Load (kg)	Frame	Falls	Trolley						Duty		Drum		Rope		*)Drum	Contactor control				Inverter control					
			D	D	D				FEM	ISO	Code	HOL	Load	Type		Gear		Motor	Speed	(tm/min)	Gear		Motor	Speed	(tm/min)
			L	H	M	W	N	F	V				(m)	(kg)			Type	Ratio		(m/min)		Type	Ratio		(m/min)
16000	E	04	M	N	F			2m	M5	C	7.5	4000	K	E	344.9	P 6	4/0.6	64	E	344.9	T 6	4	64		
										D	10.5			F	269.1	P 6	5/0.8	80	F	269.1	T 6	5	80		
										E	14			G	223.1	P 7	6.3/1.1	101	G	223.1	T 7	6.3	101		
										F	18								H	184.1	T 8	8	128		
										G	23.5								J	143.6	T 9	10	160		
										H	30.5														
										J	40														
20000	E	04	M	N	F			1Am	M4	C	7.5	5000	K	E	344.9	P 6	4/0.6	80	E	344.9	T 6	4	80		
										D	10.5			F	269.1	P 7	5/0.8	100	F	269.1	T 7	5	100		
										E	14			G	223.1	P 8	6.3/1.1	126	G	223.1	T 8	6.3	126		
										F	18								H	184.1	T 9	8	160		
										G	23.5								J	143.6	T A	10	200		
										H	30.5														
										J	40														
20000	E	06	M	N	F			3m	M6	C	5	3340	L	E	344.9	P 6	2.5/0.4	50	E	344.9	T 6	2.5	50		
										D	7			F	269.1	P 6	3.2/0.5	64	F	269.1	T 6	3.2	64		
										E	9			G	223.1	P 7	4/0.7	80	G	223.1	T 7	4	80		
										F	12								H	184.1	T 8	5	100		
										G	15.5								J	143.6	T 9	6.3	126		
										H	20														
										J	26.5														
25000	E	06	M	N	F			2m	M5	C	5	4170	L	E	344.9	P 6	2.5/0.4	63	E	344.9	T 6	2.5	63		
										D	7			F	269.1	P 6	3.2/0.5	80	F	269.1	T 6	3.2	80		
										E	9			G	223.1	P 7	4/0.7	100	G	223.1	T 7	4	100		
										F	12								H	184.1	T 8	5	125		
										G	15.5								J	143.6	T 9	6.3	158		
										H	20														
										J	26.5														
30000	E	06	M	N	F			1Am	M4	C	5	5000	L	E	344.9	P 6	2.5/0.4	75	E	344.9	T 6	2.5	75		

Load (kg)	Frame	Falls	Trolley							Duty		Drum		Rope		*Drum	Contactor control				Inverter control						
			D	D	D					FEM	ISO	Code	HOL	Load	Type		Gear		Motor	Speed	(tm/min)	Gear		Motor	Speed	(tm/min)	
			L	H	M	W	N	F	V				(m)	(kg)			Type	Ratio		(m/min)		Type	Ratio		(m/min)		
											D	7					F	269.1	P 7	3.2/0.5	96	F	269.1	T 7	3.2	96	
											E	9					G	223.1	P 8	4/0.7	120	G	223.1	T 8	4	120	
											F	12										H	184.1	T 9	5	150	
											G	15.5										J	143.6	T A	6.3	189	
											H	20															
											J	26.5															
											K	32															
32000	E	08		M		N	F		2m	M5	E	7	4000	L			E	344.9	P 6	2/0.3	64	E	344.9	T 6	2	64	
											F	9					F	269.1	P 7	2.5/0.4	80	F	269.1	T 7	2.5	80	
											G	11.5					G	223.1	P 8		102	G	223.1	T 8	3.2	102	
											H	15										H	184.1	T 9	4	128	
											J	20										J	143.6	T A	5	160	
											K	24															
40000	E	08		M		N	F		1Am	M4	E	7	5000	L			E	344.9	P 6	2/0.3	80	E	344.9	T 6	2	80	
											F	9					F	269.1	P 7	2.5/0.4	100	F	269.1	T 7	2.5	100	
											G	11.5					G	223.1	P 8	3.2/0.5	128	G	223.1	T 8	3.2	128	
											H	15										H	184.1	T 9	4	160	
											J	20										J	143.6	T A	5	200	
											K	24															
6300	E	22		M		N	F		3m	M6	E	16.5	1575	G			E	344.9	P 6	8/1.3	50	E	344.9	T 6	8	50	
											F	22	3200	+	*			F	269.1	P 6	10/1.7	63	F	269.1	T 6	10	63
											G	29.5		Gr			G	223.1	P 7	12.5/2.1	79	G	223.1	T 7	12.5	79	
											H	39										H	184.1	T 8	16	101	
											J	52										J	143.6	T 9	20	126	
											K	63.5															
											L	77															
											M	86.5															
											N	98															
8000	E	22		M		N	F		2m	M5	E	16.5	2000	G			E	344.9	P 6	8/1.3	64	E	344.9	T 6	8	64	
											F	22	4000	+	*			F	269.1	P 6	10/1.7	80	F	269.1	T 6	10	80
											G	29.5		Gr			G	223.1	P 7	12.5/2.1	100	G	223.1	T 7	12.5	100	
											H	39										H	184.1	T 8	16	128	
											J	52										J	143.6	T 9	20	160	

Load (kg)	Frame	Falls	Trolley						Duty		Drum		Rope		*)Drum	Contactor control				Inverter control					
			D	D	D				FEM	ISO	Code	HOL	Load	Type		Gear		Motor	Speed	(tm/min)	Gear		Motor	Speed	(tm/min)
			L	H	M	W	N	F	V				(m)	(kg)			Type	Ratio		(m/min)		Type	Ratio		(m/min)
											K	63.5													
											L	77													
											M	86.5													
											N	98													
10000	E	22	M	N	F			1Am M4	E	16.5	2500	G	E	344.9	P 6	8/1.3	80	E	344.9	T 6	8	80			
									F	22	5000	+	*	F	269.1	P 7	10/1.7	100	F	269.1	T 7	10	100		
									G	29.5		Gr	G	223.1	P 8	12.5/2.1	125	G	223.1	T 8	12.5	125			
									H	39								H	184.1	T 9	16	160			
									J	52								J	143.6	T A	20	200			
									K	63.5															
									L	77															
									M	86.5															
12500	E	24	M	N	F		3m M6	E	8	1600	G	E	344.9	P 6	4/0.7	50	E	344.9	T 6	4	50				
								F	11	3200	+	*	F	269.1	P 6	5/0.8	63	F	269.1	T 6	5	63			
								G	14.5		Gr	G	223.1	P 7	6.3/1.1	79	G	223.1	T 7	6.3	79				
								H	19.5								H	184.1	T 8	8	100				
								J	26								J	143.6	T 9	10	125				
								K	31.5																
								L	38.5																
								M	43																
16000	E	24	M	N	F		2m M5	E	8	2000	G	E	344.9	P 6	4/0.7	64	E	344.9	T 6	4	64				
								F	11	4000	+	*	F	269.1	P 6	5/0.8	80	F	269.1	T 6	5	80			
								G	14.5		Gr	G	223.1	P 7	6.3/1.1	101	G	223.1	T 7	6.3	101				
								H	19.5								H	184.1	T 8	8	128				
								J	26								J	143.6	T 9	10	160				
								K	31.5																
								L	38.5																
								M	43																
20000	E	24	M	N	F		1Am M4	E	8	2500	G	E	344.9	P 6	4/0.6	80	E	344.9	T 6	4	80				
								F	11	5000	+	*	F	269.1	P 7	5/0.8	100	F	269.1	T 7	5	100			

Load (kg)	Frame	Falls	Trolley							Duty		Drum		Rope		*) Drum	Contactor control				Inverter control					
			D	D	D					FEM	ISO	Code	HOL	Load	Type		Gear		Motor	Speed	(tm/min)	Gear		Motor	Speed	(tm/min)
			L	H	M	W	N	F	V				(m)	(kg)			Type	Ratio		(m/min)		Type	Ratio		(m/min)	
											G	14.5		Gr	G	223.1	P 8	6.3/1.1	126	G	223.1	T 8	6.3	126		
											H	19.5								H	184.1	T 9	8	160		
											J	26								J	143.6	T A	10	200		
											K	31.5														
											L	38.5														
											M	43														
											N	49														
20000	E	26		M		N	F		3m	M6	E	5.5	1670	H	E	344.9	P 6	2.5/0.4	63	E	344.9	T 6	2.5	63		
											F	7	3340	+	F	269.1	P 6	3.2/0.5	80	F	269.1	T 6	3.2	80		
											G	9.5		Hr	G	223.1	P 7	4/0.7	100	G	223.1	T 7	4	100		
											H	13								H	184.1	T 8	5	125		
											J	17								J	143.6	T 9	6.3	158		
											K	21														
											L	25.5														
											M	28.5														
											N	32.5														
25000	E	26		M		N	F		2m	M5	E	5.5	2085	H	E	344.9	P 6	2.5/0.4	63	E	344.9	T 6	2.5	63		
											F	7	4200	+	F	269.1	P 6	3.2/0.5	80	F	269.1	T 6	3.2	80		
											G	9.5		Hr	G	223.1	P 7	4/0.7	100	G	223.1	T 7	4	100		
											H	13								H	184.1	T 8	5	125		
											J	17								J	143.6	T 9	6.3	158		
											K	21														
											L	25.5														
											M	28.5														
											N	32.5														
30000	E	26		M		N	F		1Am	M4	E	5.5	2500	H	E	344.9	P 6	2.5/0.4	75	E	344.9	T 6	2.5	75		
											F	7	5000	+	F	269.1	P 7	3.2/0.5	96	F	269.1	T 7	3.2	96		
											G	9.5		Hr	G	223.1	P 8	4/0.7	120	G	223.1	T 8	4	120		
											H	13								H	184.1	T 9	5	150		
											J	17								J	143.6	T A	6.3	189		
											K	21														
											L	25.5														
											M	28.5														

Load (kg)	Frame	Falls	Trolley						Duty		Drum		Rope		*)Drum	Contactor control				Inverter control						
			D	D	D				FEM	ISO	Code	HOL	Load	Type		Gear		Motor	Speed	(tm/min)	Gear		Motor	Speed	(tm/min)	
			L	H	M	W	N	F	V				(m)	(kg)			Type	Ratio		(m/min)		Type	Ratio		(m/min)	
											N	32.5														
32000	E	28	M	N	F	2m	M5	F	5.5	2000	H	E	344.9	P	6	2/0.3	80	E	344.9	T	6	2	64			
								G	7	4000	+	*	F	269.1	P	7	2.5/0.4	100	F	269.1	T	7	2.5	80		
								H	9.5		Hr								G	223.1	T	8	3.2	102		
								J	13										H	184.1	T	9	4	128		
								K	15.5										J	143.6	T	A	5	160		
								L	19																	
								M	21.5																	
40000	E	28	M	N	F	1Am	M4	F	5.5	2500	H	E	344.9	P	6	2/0.3	80	E	344.9	T	6	2	80			
								G	7	5000	+	*	F	269.1	P	7	2.5/0.4	100	F	269.1	T	7	2.5	100		
								H	9.5		Hr		G	223.1	P	8	3.2/0.5	128	G	223.1	T	8	3.2	128		
								J	13										H	184.1	T	9	4	160		
								K	15.5										J	143.6	T	A	5	200		
								L	19																	
								M	21.5																	
12500	F	22	M	F	3m	M6	F	15.5	3125	K	E	344.9	2P	6	8/1.2	100	E	344.9	2T	6	8	100				
							G	20.5	6300	+	*	F	269.1	2P	6	10/1.6	125	F	269.1	2T	6	10	125			
							H	27.5		Kr		G	223.1	2P	7	12.5/2.1	157	G	223.1	2T	7	12.5	157			
							J	37.5										H	184.1	2T	8	16	200			
							K	46										J	143.6	2T	9	20	250			
							L	55.5																		
							M	62.5																		
16000	F	22	M	F	2m	M5	F	15.5	4000	K	E	344.9	2P	6	8/1.2	128	E	344.9	2T	6	8	128				
							G	20.5	8000	+	*	F	269.1	2P	6	10/1.6	160	F	269.1	2T	6	10	160			
							H	27.5		Kr		G	223.1	2P	7	12.5/2.1	200	G	223.1	2T	7	12.5	200			
							J	37.5										H	184.1	2T	8	16	250			
							K	46										J	143.6	2T	9	20	320			
							L	55.5																		
							M	62.5																		

Load (kg)	Frame	Falls	Trolley							Duty		Drum		Rope		*)Drum	Contactor control				Inverter control					
			D	D	D					FEM	ISO	Code	HOL	Load	Type		Gear		Motor	Speed	(tm/min)	Gear		Motor	Speed	(tm/min)
			L	H	M	W	N	F	V				(m)	(kg)			Type	Ratio		(m/min)		Type	Ratio		(m/min)	
											N	71														
20000	F	22	M	F	1Am	M4	F	15.5	5000	K		E	344.9	2P	6	8/1.2	160	E	344.9	2T	6	8	160			
								20.5	10000	+	*	F	269.1	2P	7	10/1.6	200	F	269.1	2T	7	10	200			
								27.5		Kr								G	223.1	2T	8	12.5	250			
								37.5										H	184.1	2T	9	16	320			
								46																		
								55.5																		
								62.5																		
25000	F	24	M	F	3m	M6	F	7.5	3125	K		E	344.9	2P	6	4/0.6	100	E	344.9	2T	6	4	100			
								10	6300	+	*	F	269.1	2P	6	5/0.8	125	F	269.1	2T	6	5	125			
								13.5		Kr		G	223.1	2P	7	6.3/1	158	G	223.1	2T	7	6.3	158			
								18.5										H	184.1	2T	8	8	200			
								23										J	143.6	2T	9	10	250			
								27.5																		
								31																		
32000	F	24	M	F	2m	M5	F	7.5	4000	K		E	344.9	2P	6	4/0.6	128	E	344.9	2T	6	4	128			
								10	8000	+	*	F	269.1	2P	6	5/0.8	160	F	269.1	2T	6	5	160			
								13.5		Kr		G	223.1	2P	7	6.3/1	202	G	223.1	2T	7	6.3	202			
								18.5										H	184.1	2T	8	8	250			
								23										J	143.6	2T	9	10	320			
								27.5																		
								31																		
40000	F	24	M	F	1Am	M4	F	7.5	5000	K		E	344.9	2P	6	4/0.6	160	E	344.9	2T	6	4	160			
								10	10000	+	*	F	269.1	2P	7	5/0.8	200	F	269.1	2T	7	5	200			
								13.5		Kr								G	223.1	2T	8	6.3	250			
								18.5										H	184.1	2T	9	8	320			
								23																		
								27.5																		
								31																		

Load (kg)	Frame	Falls	Trolley						Duty		Drum		Rope		*)Drum	Contactor control				Inverter control					
			D	D	D				FEM	ISO	Code	HOL	Load	Type		Gear		Motor	Speed	(tm/min)	Gear		Motor	Speed	(tm/min)
			L	H	M	W	N	F	V				(m)	(kg)			Type	Ratio		(m/min)		Type	Ratio		(m/min)
40000	F	26	M	F	3m	M6	F	5	3333	L	+	*	E	344.9	2P	6	2.5/0.4	100	E	344.9	2T	6	2.5	100	
													F	269.1	2P	6	3.2/0.5	128	F	269.1	2T	6	3.2	128	
													G	223.1	2P	7	4/0.6	160	G	223.1	2T	7	4	160	
																			H	184.1	2T	8	5	200	
																			J	143.6	2T	9	6.3	250	
50000	F	26	M	F	2m	M5	F	5	4167	L	+	*	E	344.9	2P	6	2.5/0.4	125	E	344.9	2T	6	2.5	125	
													F	269.1	2P	6	3.2/0.5	160	F	269.1	2T	6	3.2	160	
													G	223.1	2P	7	4/0.6	200	G	223.1	2T	7	4	200	
																			H	184.1	2T	8	5	250	
																			J	143.6	2T	9	6.3	315	
60000	F	26	M	F	1Am	M4	F	5	5000	L	+	*	E	344.9	2P	6	2.5/0.4	150	E	344.9	2T	6	2.5	150	
													F	269.1	2P	7	3.2/0.5	192	F	269.1	2T	7	3.2	192	
													G						G	223.1	2T	8	4	240	
																			H	184.1	2T	9	5	300	
63000	F	28	M	F	2m	M5	H	6.5	3978	L			E	344.9	2P	6	2/0.3	126	E	344.9	2T	6	2	126	
							J	9	7875	+	*	F	269.1	2P	6	2.5/0.4	158	F	269.1	2T	6	2.5	158		
							K	11		Lr	G	223.1	2P	7	3.2/0.5	200	G	223.1	2T	7	3.2	200			
							L	13.5									H	184.1	2T	8	4	250			
							M	15.5									J	143.6	2T	9	5	315			
							N	17.5																	
80000	F	28	M	F	1Am	M4	H	6.5	5000	L			E	344.9	2P	6	2/0.3	160	E	344.9	2T	6	2	160	
							J	9	10000	+	*	F	269.1	2P	7	2.5/0.4	200	F	269.1	2T	7	2.5	200		
							K	11		Lr							G	223.1	2T	8	3.2	250			

Load (kg)	Frame	Falls	Trolley							Duty		Drum		Rope		*) Drum	Contactor control				Inverter control						
			D	D	D					FEM	ISO	Code	HOL	Load	Type		Gear		Motor	Speed	(tm/min)	Gear		Motor	Speed	(tm/min)	
			L	H	M	W	N	F	V				(m)	(kg)			Type	Ratio		(m/min)		Type	Ratio		(m/min)		
													L	13.5								H	184.1	2T	9	4	320
													M	15.5													
													N	17.5													

\*) Drum load

### 3 HOISTING MOTORS

#### 3.1 Motor data, 2 - speed pole change motors, 50 Hz

Duty Group Fem/ISO	Q motor data			PX		P1		P2		P3		
				MF09ZA106		MF10M-106		MF10Z-106		MF10X-106		
		Rated power	kW	1.5	0.25	1.8	0.25	3.6	0.5	4.5	0.7	
		Synchronous speed	RPM	3000	500	3000	500	3000	500	3000	500	
		Brake torque	Nm	14		21		21		42		
		Max el. br. torque	Nm		-		32		63		77	
		El. br. torque	Nm		-		12.6		25		38	
		Power fact. start		0.89	0.77	0.8	0.83	0.83	0.78	0.84	0.77	
		Starting torque	Nm	11	10	12.4	10.7	25	22	34	28	
		Weight	kg	21		22.6		30.6		35		
		Brake inertia	kgm <sup>2</sup>	0.00017		0.00017		0.00017		0.00045		
Inertia w/o brake	kgm <sup>2</sup>	0.0039		0.0027		0.0049		0.0059				
2m/M5 240 Starts/h 40 % ED 30/3.5 min	300 starts/h 60 % ED	Load	tm/min	8 *)		10		20		25		
		Nominal power	kW	1.5	0.25	1.8	0.25	3.6	0.5	4.5	0.7	
		Nominal torque	Nm	5.4	5.4	6.1	6.1	12.3	12.3	15.3	15.3	
		Nominal speed	RPM	2750	400	2780	420	2800	400	2750	415	
		Short time duty	min	30	15	60	15	60	15	30	15	
		Power factor		0.88	0.66	0.82	0.67	0.87	0.63	0.92	0.61	
		Efficiency		0.66	0.23	0.66	0.24	0.73	0.30	0.72	0.30	
3m/M6 300 Starts/h 50 % ED 30/4 min	300 starts/h 60 % ED	Load	tm/min			8		16		20		
		Nominal power	kW			1.5	0.2	2.9	0.4	3.6	0.5	
		Nominal torque	Nm			4.9	4.9	9.8	9.8	12.3	12.3	
		Nominal speed	RPM			2830	435	2850	420	2830	430	
		Short time duty	min									
		Power factor				0.78	0.64	0.84	0.58	0.89	0.56	
	300 starts/h 60 % ED	Efficiency				0.64	0.22	0.76	0.29	0.74	0.29	
		Load	tm/min			6.3		12.5		16		
		Nominal power	kW			1.2	0.16	2.4	0.35	2.9	0.4	
		Nominal torque	Nm			3.9	3.9	7.7	7.7	9.8	9.8	
		Nominal speed	RPM			2860	445	2890	435	2870	440	
		Short time duty	min									
	300 starts/h 60 % ED	Power factor				0.73	0.61	0.77	0.53	0.85	0.51	
		Efficiency					0.61	0.18	0.75	0.26	0.73	0.27
		Load	tm/min			5		10		12.5		
		Nominal power	kW			0.9	0.12	1.8	0.25	2.4	0.35	
		Nominal torque	Nm			3	3	6.1	6.1	7.7	7.7	
		Nominal speed	RPM			2890	460	2920	450	2900	450	
	300 starts/h 60 % ED	Short time duty	min									
		Power factor				0.66	0.58	0.69	0.50	0.81	0.48	
		Efficiency				0.58	0.15	0.73	0.23	0.72	0.24	

\*) Q motor data for PX 240 starts/h, 40% ED



For Duty Group 1Am/M4 use the motor values of Duty Group 2m/M5.

Duty Group Fem/ISO	Q motor data			P4		P5		P6		P7	
				MF11XA106		MF11X-106		MF13Z-106		MF13X-106	
		Rated power	kW	7.5	1.2	9	1.4	15	2.5	18	3
		Synchronous speed	RPM	3000	500	3000	500	3000	500	3000	500
		Brake torque	Nm	54		54		100		130	
		Max el. br. torque	Nm		105		107		190		225
		El. br. torque	Nm		56		57		84		111
		Power fact. start		0.79	0.69	0.77	0.69	0.67	0.68	0.62	0.65
		Starting torque	Nm	57	48	67	56	107	84	120	111
		Weight	kg	51		59		86		99	
		Brake inertia	kgm <sup>2</sup>	0.0007		0.0007		0.0007		0.0017	
		Inertia w/o brake	kgm <sup>2</sup>	0.0101		0.0116		0.036		0.043	
2m/M5 240 starts/h 40 % ED 30/3.5 min	300 starts/h 60 % ED	Load	tm/min	40		50		80		100	
		Nominal power	kW	7.5	1.2	9	1.4	15	2.5	18	3
		Nominal torque	Nm	24	24	30	30	48	48	62	62
		Nominal speed	RPM	2650	355	2680	335	2740	420	2770	425
		Short time duty	min	30	12	30	10	30	15	30	15
		Power factor		0.90	0.56	0.90	0.61	0.87	0.59	0.91	0.56
		Efficiency		0.73	0.28	0.72	0.28	0.78	0.45	0.80	0.47
3m/M6 300 starts/h 50 % ED 30/4 min	300 starts/h 60 % ED	Load	tm/min	32		40		63		80	
		Nominal power	kW	6	1	7.5	1.2	12	2	15	2.5
		Nominal torque	Nm	19.2	19.2	24	24	38	38	48	48
		Nominal speed	RPM	2730	390	2760	370	2810	440	2820	440
		Short time duty	min								
		Power factor		0.87	0.52	0.87	0.56	0.82	0.52	0.89	0.47
	300 starts/h 60 % ED	Load	tm/min	25		32		50		63	
		Nominal power	kW	4.5	0.7	6	1	9	1.4	12	2
		Nominal torque	Nm	15.3	15.3	19.2	19.2	30	30	38	38
		Nominal speed	RPM	2800	420	2820	400	2860	455	2865	455
		Short time duty	min								
		Power factor		0.82	0.47	0.84	0.52	0.78	0.48	0.87	0.41
	300 starts/h 60 % ED	Load	tm/min	20		25		40		50	
		Nominal power	kW	3.6	0.5	4.5	0.7	7.5	1.2	9	1.4
		Nominal torque	Nm	12.3	12.3	15.3	15.3	24	24	30	30
		Nominal speed	RPM	2840	440	2870	425	2900	465	2900	465
		Short time duty	min								
		Power factor		0.76	0.45	0.80	0.47	0.70	0.42	0.84	0.36
		Efficiency		0.74	0.23	0.79	0.25	0.77	0.34	0.82	0.35



For Duty Group 1Am/M4 use the motor values of Duty Group 2m/M5.

Duty Group Fem/ISO	Q motor data			P8*	
				MF13XA106	
		Rated power	kW	23	3.5
		Synchronous speed	RPM	3000	500
		Brake torque	Nm	200	
		Max el. br. torque	Nm		290
		El. br. torque	Nm		150
		Power fact. start		0.73	0.67
		Starting torque	Nm	165	140
		Weight	kg	99	
		Brake inertia	kgm <sup>2</sup>	0.0017	
		Inertia w/o brake	kgm <sup>2</sup>	0.043	
1Am/M4		Load	tm/min	125	
180	300	Nominal power	kW	23	3.5
starts/h	starts/h	Nominal torque	Nm	76	76
30 % ED	50 % ED	Nominal speed	RPM	2790	420
15/3 min		Short time duty	min	15	10
		Power factor		0.84	0.57
		Efficiency		0.83	0.44

\*) Note! P8 hoisting motor for 1Am use only. External fan as standard.

### 3.2 Motor currents, 2 - speed pole change motors, 50 Hz

Nominal voltage				Currents							
				230 V		400 V		500 V		660 V	
Used in voltage range				220...240 V		380...415 V		500...525 V		660...690 V	
			tm/min	fast	slow	fast	slow	fast	slow	fast	slow
PX	Starting current	(A)				15	3.0				
<b>MF09ZA106</b>	Nominal current	(A)									
			8			3.7	2.2				
	No-load current	(A)				2.1	2.1				
P1	Starting current	(A)		35	6.1	20	3.6	16	2.9	12	2.2
<b>MF10M-106</b>	Nominal current	(A)									
			10	8.5	4.9	4.9	2.8	3.9	2.2	3.0	1.7
			8	7.5	4.3	4.3	2.5	3.4	2.0	2.6	1.5
			6.3	7.0	4.3	4	2.5	3.2	2.0	2.4	1.5
			5	6.6	4.3	3.8	2.5	3.0	2.0	2.3	1.5
	No-load current	(A)		6.3	4.9	3.6	2.8	2.9	2.2	2.2	1.7
P2	Starting current	(A)		68	11.7	39	6.7	31	5.4	24	4.1
<b>MF10Z-106</b>	Nominal current	(A)									
			20	14	7.1	8.2	4.1	6.6	3.3	5.0	2.5
			16	12.2	6.6	7	3.8	5.6	3.0	4.2	2.3
			12.5	10.4	6.4	6	3.7	4.8	3.0	3.6	2.2
			10	9.2	6.6	5.3	3.8	4.2	3.0	3.2	2.3
	No-load current	(A)		7.8	7.5	4.5	4.3	3.6	3.4	2.7	2.6
P3	Starting current	(A)		77	15	44	8.6	35	6.9	27	5.2
<b>MF10X-106</b>	Nominal current	(A)									
			25	17	9.6	9.9	5.5	7.9	4.4	6.0	3.3
			20	14.6	8.7	8.4	5	6.7	4.0	5.1	3.0
			16	12.2	8.7	7	5	5.6	4.0	4.2	3.0
			12.5	10.6	8.9	6.1	5.1	4.9	4.1	3.7	3.1
	No-load current	(A)		7.7	9.6	4.4	5.5	3.5	4.4	2.7	3.3
P4	Starting current	(A)		118	22	68	12.7	54	10.2	41	7.7
<b>MF11XA106</b>	Nominal current	(A)									
			40	30	17	17	9.5	14	7.6	10	5.8
			32	24	15	13.7	8.6	11.0	6.9	8.3	5.2
			25	19	15	11	8.6	8.8	6.9	6.7	5.2
			20	17	15	10	8.6	8.0	6.9	6.1	5.2
	No-load current	(A)		12	16	7.0	9.2	5.6	7.4	4.2	5.6
P5	Starting current	(A)		144	28	83	16	66	12.8	50	9.7
<b>MF11X-106</b>	Nominal current	(A)									
			50	33	19	19	11	15	8.8	12	6.7
			40	28	16	16	9	13	7.2	9.9	5.5
			32	23	15	13.5	8.9	10.8	7.1	8.2	5.4
			25	19	15	11.1	8.9	8.9	7.1	6.7	5.4
	No-load current	(A)		14	17	7.8	10	6.2	8.0	4.7	6.1
P6	Starting current	(A)		252	43	145	25	116	20	88	15
<b>MF13Z-106</b>	Nominal current	(A)									
			80	56	24	32	14	26	11	19	8.5
			63	43	21	25	12	20	9.6	15	7.3
			50	38	21	22	12	18	9.6	13	7.3
			40	35	21	20	12	16	9.6	12	7.3
	No-load current	(A)		28	23	16	13	13	10.4	9.7	7.9
P7	Starting current	(A)		339	59	195	34	156	27.2	118	21
<b>MF13X-106</b>	Nominal current	(A)									
			100	66	31	38	18	30	14	23	11
			80	49	26	28	15	22	12.0	17	9.1
			63	40	26	23	15	18	12.0	14	9.1

				Currents							
Nominal voltage				230 V		400 V		500 V		660 V	
Used in voltage range				220...240 V		380...415 V		500...525 V		660...690 V	
			tm/min	fast	slow	fast	slow	fast	slow	fast	slow
			50	33	26	19	15	15	12.0	11.5	9.1
	No-load current	(A)		21	31	12	18	9.6	14.4	7.3	10.9
P8	Starting current	(A)		389	68	212	39	170	31	128	24
<b>MF13XA106</b>	Nominal current	(A)									
			125	85	40	49	23	39	18	30	14
	No-load current	(A)		43	38	25	22	20	18	15	13

### 3.3 Motor data, 2 - speed pole change motors, 60 Hz

Duty Group Fem/ISO	Q motor data			PX		P1		P2		P3	
				MF09ZA106		MF10M-106		MF10Z-106		MF10X-106	
		Rated power	kW	1.8	0.3	2.2	0.3	4.3	0.7	5.4	0.9
		Synchronous speed	RPM	3600	600	3600	600	3600	600	3600	600
		Brake torque	Nm	14		21		21		42	
		Max el. br. torque	Nm		-		32		63		77
		El. br. torque	Nm		-		12.6		25		38
		Power fact. start		0.87	0.73	0.76	0.81	0.77	0.73	0.78	0.74
		Starting torque	Nm	11	10	12.4	10.7	24.6	21.7	34	28
		Weight	kg	21		22.6		30.6		35	
		Brake inertia	kgm <sup>2</sup>	0.00012		0.00017		0.00017		0.00045	
		Inertia w/o brake	kgm <sup>2</sup>	0.0039		0.0027		0.0049		0.0059	
2m/M5		Load	tm/min	9.6 *)		12		24		30	
240	300	Nominal power	kW	1.8	0.3	2.2	0.3	4.3	0.7	5.4	0.9
starts/h	starts/h	Nominal torque	Nm	5.4	5.4	6.1	6.1	12.3	12.3	15.3	15.3
40 % ED	60 % ED	Nominal speed	RPM	3350	500	3410	525	3400	500	3350	495
30/3.5 min		Short time duty	min	30	15	60	15	60	15	30	15
		Power factor		0.90	0.68	0.83	0.65	0.89	0.61	0.93	0.60
		Efficiency		0.68	0.25	0.71	0.28	0.75	0.38	0.74	0.36
3m/M6		Load	tm/min			9.6		19.2		24	
300	300	Nominal power	kW			1.8	0.25	3.5	0.5	4.3	0.7
starts/h	starts/h	Nominal torque	Nm			4.9	4.9	9.8	9.8	12.3	12.3
50 % ED	60 % ED	Nominal speed	RPM			3450	540	3450	520	3410	530
30/4 min		Short time duty	min								
		Power factor				0.80	0.58	0.87	0.54	0.91	0.53
		Efficiency				0.71	0.25	0.75	0.36	0.75	0.34
		Load	tm/min			7.6		15		19.2	
	300	Nominal power	kW			1.4	0.2	2.9	0.4	3.5	0.5
	starts/h	Nominal torque	Nm			3.9	3.9	7.7	7.7	9.8	9.8
	60 % ED	Nominal speed	RPM			3480	550	3490	540	3450	540
		Short time duty	min								
		Power factor				0.75	0.55	0.82	0.49	0.88	0.49
		Efficiency				0.68	0.21	0.74	0.31	0.75	0.31
		Load	tm/min			6		12		15	
	300	Nominal power	kW			1.1	0.15	2.2	0.3	2.9	0.4
	starts/h	Nominal torque	Nm			3	3	6.1	6.1	7.7	7.7
	60 % ED	Nominal speed	RPM			3510	565	3520	550	3490	550
		Short time duty	min								
		Power factor				0.67	0.52	0.76	0.45	0.85	0.45
		Efficiency				0.66	0.18	0.71	0.28	0.73	0.28

\*) Q motor data for PX 240 starts/h, 40% ED



For Duty Group 1Am/M4 use the motor values of Duty Group 2m/M5.

Duty Group Fem/ISO	Q motor data			P4		P5		P6		P7	
				MF11XA106		MF11X-106		MF13Z-106		MF13X-106	
		Rated power	kW	9	1.4	11	1.6	18	3	21	3.5
		Synchronous speed	RPM	3600	600	3600	600	3600	600	3600	600
		Brake torque	Nm	54		54		100		130	
		Max el. br. torque	Nm		105		112		182		205
		El. br. torque	Nm		56		64		82		101
		Power fact. start		0.73	0.67	0.75	0.68	0.60	0.64	0.55	0.59
		Starting torque	Nm	54	44	63	51	102	82	114	101
		Weight	kg	51		59		86		99	
		Brake inertia	kgm2	0.0007		0.0007		0.0007		0.0017	
		Inertia w/o brake	kgm2	0.0101		0.0116		0.036		0.043	
2m/M5		Load	tm/min	48		60		96		120	
240	300	Nominal power	kW	9	1.4	11	1.6	18	3	21	3.5
starts/h	starts/h	Nominal torque	Nm	24	24	30	30	48	48	62	62
40 % ED	60 % ED	Nominal speed	RPM	3230	450	3250	440	3320	515	3360	520
30/3.5 min		Short time duty	min	30	12	30	10	30	15	30	15
		Power factor		0.90	0.54	0.91	0.57	0.88	0.59	0.92	0.55
		Efficiency		0.74	0.34	0.75	0.35	0.80	0.50	0.81	0.52
3m/M6		Load	tm/min	38		48		76		96	
300	300	Nominal power	kW	7.2	1.2	9	1.4	14	2.3	18	3
starts/h	starts/h	Nominal torque	Nm	19.2	19.2	24	24	38	38	48	48
50 % ED	60 % ED	Nominal speed	RPM	3315	490	3320	470	3390	540	3410	540
30/4 min		Short time duty	min								
		Power factor		0.88	0.49	0.90	0.53	0.85	0.52	0.90	0.47
		Efficiency		0.76	0.33	0.77	0.35	0.82	0.48	0.83	0.49
		Load	tm/min	30		38		60		76	
	300	Nominal power	kW	5.4	0.9	7.2	1.2	11	1.6	14	2.3
	starts/h	Nominal torque	Nm	15.3	15.3	19.2	19.2	30	30	38	38
	60 % ED	Nominal speed	RPM	3390	520	3395	500	3445	555	3460	555
		Short time duty	min								
		Power factor		0.85	0.43	0.87	0.47	0.82	0.48	0.88	0.41
		Efficiency		0.75	0.31	0.77	0.34	0.82	0.46	0.83	0.46
		Load	tm/min	24		30		48		60	
	300	Nominal power	kW	4.3	0.7	5.4	0.9	9	1.4	11	1.6
	starts/h	Nominal torque	Nm	12.3	12.3	15.3	15.3	24	24	30	30
	60 % ED	Nominal speed	RPM	3440	540	3450	525	3495	565	3495	565
		Short time duty	min								
		Power factor		0.78	0.39	0.83	0.42	0.74	0.42	0.85	0.37
		Efficiency		0.74	0.28	0.77	0.31	0.82	0.39	0.83	0.41



For Duty Group 1Am/M4 use the motor values of Duty Group 2m/M5.

Duty Group Fem/ISO	Q motor data			P8*	
				MF13XA106	
		Rated power	kW	25	3.8
		Synchronous speed	RPM	3600	600
		Brake torque	Nm	200	
		Max el. br. torque	Nm		290
		El. br. torque	Nm		150
		Power fact. start		0.68	0.69
		Starting torque	Nm	160	140
		Weight	kg	99	
		Brake inertia	kgm <sup>2</sup>	0.0017	
		Inertia w/o brake	kgm <sup>2</sup>	0.043	
1Am/M4		Load	tm/min	135	
180	300	Nominal power	kW	25	3.8
starts/h	starts/h	Nominal torque	Nm	69	69
30 % ED	50 % ED	Nominal speed	RPM	3430	530
15/3 min		Short time duty	min	15	10
		Power factor		0.87	0.54
		Efficiency		0.86	0.49

\*) Note! P8 hoisting motor for 1Am use only. External fan as standard.

### 3.4 Motor currents, 2 - speed pole change motors, 60 Hz

Nominal voltage			Currents								
			220 V		380 V		460 V		575 V		
Used in voltage range			208...230 V		360...400 V		440...480 V		575...600 V		
		tm/min	fast	slow	fast	slow	fast	slow	fast	slow	
PX	Starting current	(A)						15	3.0		
<b>MF09ZA106</b>	Nominal current	(A)									
		9.6						3.7	2.2		
	No-load current	(A)						2.1	2.1		
P1	Starting current	(A)	42	9	23	4.7					
<b>MF10M-106</b>	Nominal current	(A)									
		12	9.8	5.9	5.0	3.4	4.7	2.8	3.6	2.2	
		9.6	8.8	5.2	5.1	3.0	4.2	2.5	3.4	2.0	
		7.6	7.9	5.2	4.6	3.0	3.8	2.5	3.0	2.0	
		6	7.1	5.2	4.1	3.0	3.4	2.5	2.7	2.0	
	No-load current	(A)	5.2	5.9	3	3.1	2.5	2.8	2	2.1	
P2	Starting current	(A)	90	15	52	8.8	43	7.3	34	5.8	
<b>MF10Z-106</b>	Nominal current	(A)									
		24	17	8.4	10	4.8	8.3	4.0	6.6	3.2	
		19.2	15.3	8.2	8.8	4.7	7.3	3.9	5.8	3.1	
		15	12.5	8.2	7.3	4.7	6	3.9	4.8	3.1	
		12	11.5	8.2	6.7	4.7	5.5	3.9	4.4	3.1	
	No-load current	(A)	7.9	8.6	4.6	5.0	3.8	4.1	3.0	3.3	
P3	Starting current	(A)	102	18	59	10.2	49	8.4	39	6.7	
<b>MF10X-106</b>	Nominal current	(A)									
		30	22	11	13	6.5	10	5.4	8.2	4.3	
		24	18	10.2	10.3	5.9	8.5	4.9	6.8	3.9	
		19.2	15	10.2	8.7	5.9	7.2	4.9	5.8	3.9	
		15	13	10.2	7.3	5.9	6	4.9	4.8	3.9	
	No-load current	(A)	8.4	11.3	4.8	6.5	4	5.4	3.2	4.3	
P4	Starting current	(A)	146	29	85	17	70.0	14.0	56	11.2	
<b>MF11XA106</b>	Nominal current	(A)									
		48	36	19	21	11	17	9.1	14	7.3	
		38	27	17	16	10.0	13	8.3	10.4	6.6	
		30	23	17	13	10.0	11	8.3	8.8	6.6	
		24	21	17	12	10.0	10	8.3	8.0	6.6	
	No-load current	(A)	12.5	18	7.3	10.7	6.0	8.8	4.8	7.0	
P5	Starting current	(A)	167	31	97	18.2	80	15	64	12.0	
<b>MF11X-106</b>	Nominal current	(A)									
		60	42	21	24	12	20	10	16	8.0	
		48	33	18	19	10.5	16	8.7	12.8	7.0	
		38	28	18	16	10.3	13.5	8.5	10.8	6.8	
		30	23	18	13	10.3	11	8.5	8.8	6.8	
	No-load current	(A)	14	20	8.1	11.5	6.7	9.5	5.4	7.6	
P6	Starting current	(A)	312	52	180	30	149	25	119	20	
<b>MF13Z-106</b>	Nominal current	(A)									
		96	67	27	39	16	32	13	26	10	
		76	54	27	31	15.7	26	13	21	10.4	
		60	46	25	27	14.5	22	12	18	9.6	
		48	36	25	21	14.5	17	12	13.6	9.6	
	No-load current	(A)	27	25	16	14.5	13	12	10.4	9.6	
P7	Starting current	(A)	433	73	251	42	207	35	166	28	
<b>MF13X-106</b>	Nominal current	(A)									
		120	79	33	46	19	38	16	30	13	
		96	59	29	34	17	28	14	22	11.2	
		76	46	29	27	17	22	14	18	11.2	

				Currents							
Nominal voltage				220 V		380 V		460 V		575 V	
Used in voltage range				208...230 V		360...400 V		440...480 V		575...600 V	
			tm/min	fast	slow	fast	slow	fast	slow	fast	slow
			60	40	29	23	17	19	14	15	11.2
	No-load current	(A)		21	33	12	19	10	16	8.0	12.8
P8	Starting current	(A)		460	121	266	70	220	35	176	28
<b>MF13XA106</b>	Nominal current	(A)									
			135	98	47	57	27	47	22	38	18
	No-load current	(A)		40	41	23	24	19	20	15.2	16

### 3.5 Motor data, inverter motors, 100 Hz

Duty Group Fem/ISO	Q motor data			T1	T2	T3	T4	T5	T6
				MF10MA200	MF10MB200	MF10MC200	MF11MA200	MF11MB200	MF13Z-200
		Rated power	kW	1.8	3.6	4.5	7.5	9	15
		Synchronous speed	RPM	3000	3000	3000	3000	3000	3000
		Brake torque	Nm	21	42	42	54	54	100
		Max el. br. torque	Nm						
		El. br. torque	Nm						
		Power fact. start							
		Pull-out torque	Nm	16.6	32	40	80	80	165
		Speed at 80% of pull-out torque	rpm	2500	2500	2410	2500	2500	2700
		Starting torque	Nm						
		Weight	kg	23	23	23	37	37	59
		Brake inertia	kgm <sup>2</sup>	0.00017	0.00017	0.00045	0.0007	0.0007	0.0007
		Inertia w/o brake	kgm <sup>2</sup>	0.0027	0.0027	0.0027	0.0075	0.0075	0.024
2m/M5		Load	tm/min	10	20	25	40	50	80
240	300	Nominal power	kW	1.8	3.6	4.5	7.5	9	15
starts/h	starts/h	Nominal torque	Nm	6.1	12.3	15.3	24	30	48
40 % ED	60 % ED	Nominal speed	RPM	2830	2790	2780	2860	2830	2910
30/3.5 min		Short time duty	min	60	60	60	30	30	30
		Power factor		0.74	0.75	0.78	0.74	0.78	0.85
		Efficiency		0.73	0.75	0.77	0.81	0.81	0.86
3m/M6		Load	tm/min	8	16	20	32	40	63
300	300	Nominal power	kW	1.5	2.9	3.6	6	7.5	12
starts/h	starts/h	Nominal torque	Nm	4.9	9.8	12.3	19.2	24	38
50 % ED	60 % ED	Nominal speed	RPM	2860	2830	2830	2900	2860	2925
30/4 min		Short time duty	min						
		Power factor		0.69	0.69	0.72	0.67	0.74	0.79
		Efficiency		0.71	0.74	0.77	0.80	0.81	0.86
		Load	tm/min	6.3	12.5	16	25	32	50
	300	Nominal power	kW	1.2	2.4	2.9	4.5	6	9
	starts/h	Nominal torque	Nm	3.9	7.7	9.8	15.3	19.2	30
	60 % ED	Nominal speed	RPM	2880	2870	2880	2925	2900	2940
		Short time duty	min						
		Power factor		0.64	0.63	0.65	0.61	0.67	0.72
		Efficiency		0.67	0.73	0.76	0.78	0.80	0.84
		Load	tm/min	5	10	12.5	20	25	40
	300	Nominal power	kW	0.9	1.8	2.4	3.6	4.5	7.5
	starts/h	Nominal torque	Nm	3	6.1	7.7	12.3	15.3	24
	60 % ED	Nominal speed	RPM	2905	2900	2905	2940	2925	2960
		Short time duty	min						
		Power factor		0.57	0.55	0.58	0.55	0.61	0.68
		Efficiency		0.63	0.69	0.74	0.76	0.78	0.81



For Duty Group 1Am/M4 use the values of Duty Group 2m/M5.

Duty Group Fem/ISO	Q motor data			T7	T8	T9	TA
				MF13ZA200	MF13ZB200	MF13ZC200	MF13X-200
		Rated power	kW	18	23	28	35
		Synchronous speed	RPM	3000	3000	3000	3000
		Brake torque	Nm	130	200	200	200
		Max el. br. torque	Nm				
		El. br. torque	Nm				
		Power fact. start					
		Pull-out torque	Nm	165	200	275	350
		Speed at 80% of pull-out torque	rpm	2700	2720	2710	2750
		Starting torque	Nm				
		Weight	kg	59	72	85	99
		Brake inertia	kgm <sup>2</sup>	0.0017	0.0017	0.0017	0.0017
		Inertia w/o brake	kgm <sup>2</sup>	0.024	0.030	0.036	0.043
2m/M5		Load	tm/min	100	125	160	200
240	300	Nominal power	kW	18	23	28	35
starts/h	starts/h	Nominal torque	Nm	62	76	96	116
40 % ED	60 % ED	Nominal speed	RPM	2890	2890	2880	2880
30/3.5 min		Short time duty	min	30	30	30	30
		Power factor		0.87	0.88	0.87	0.85
		Efficiency		0.87	0.89	0.89	0.90
3m/M6		Load	tm/min	80	100	125	160
300	300	Nominal power	kW	15	18	23	28
starts/h	starts/h	Nominal torque	Nm	48	62	76	96
50 % ED	60 % ED	Nominal speed	RPM	2910	2910	2920	2930
30/4 min		Short time duty	min				
		Power factor		0.85	0.86	0.84	0.83
		Efficiency		0.86	0.89	0.89	0.89
		Load	tm/min	63	80	100	125
	300	Nominal power	kW	12	15	18	23
	starts/h	Nominal torque	Nm	38	48	62	76
	60 % ED	Nominal speed	RPM	2925	2930	2935	2940
		Short time duty	min				
		Power factor		0.79	0.82	0.80	0.78
		Efficiency		0.86	0.89	0.88	0.89
		Load	tm/min	50	63	80	100
	300	Nominal power	kW	9	12	15	18
	starts/h	Nominal torque	Nm	30	38	48	62
	60 % ED	Nominal speed	RPM	2940	2940	2950	2950
		Short time duty	min				
		Power factor		0.72	0.77	0.74	0.73
		Efficiency		0.84	0.88	0.87	0.88



For Duty Group 1Am/M4 use the values of Duty Group 2m/M5.

### 3.6 Motor data, inverter motors, 120 Hz

Duty Group Fem/ISO	Q motor data			T1	T2	T3	T4	T5	T6
				MF10MA200	MF10MB200	MF10MC200	MF11MA200	MF11MB200	MF13Z-200
		Rated power	kW	2.2	4.3	5.4	9	11	18
		Synchronous speed	RPM	3600	3600	3600	3600	3600	3600
		Brake torque	Nm	21	21	42	54	54	100
		Max el. br. torque	Nm						
		El. br. torque	Nm						
		Power fact. start							
		Pull-out torque	Nm	16	31	39	76	76	152
		Speed at 80% of pull-out torque	rpm	3100	3100	3040	3100	3100	3300
		Starting torque	Nm						
		Weight	kg	23	23	23	37	37	59
		Brake inertia	kgm <sup>2</sup>	0.00017	0.00017	0.00045	0.0007	0.0007	0.0007
		Inertia w/o brake	kgm <sup>2</sup>	0.0027	0.0027	0.0027	0.0075	0.0075	0.024
2m/M5		Load	tm/min	12	24	30	48	60	96
240	300	Nominal power	kW	2.2	4.3	5.4	9	11	18
starts/h	starts/h	Nominal torque	Nm	6.1	12.3	15.3	24	30	48
40 % ED	60 % ED	Nominal speed	RPM	3420	3370	3340	3440	3410	3500
30/3.5 min		Short time duty	min	60	60	60	30	30	30
		Power factor		0.75	0.77	0.80	0.75	0.78	0.85
		Efficiency		0.71	0.76	0.77	0.78	0.81	0.86
3m/M6		Load	tm/min	9.6	19.2	24	38	48	76
300	300	Nominal power	kW	1.8	3.5	4.3	7.2	9	14
starts/h	starts/h	Nominal torque	Nm	4.9	9.8	12.3	19.2	24	38
50 % ED	60 % ED	Nominal speed	RPM	3450	3415	3390	3485	3440	3520
30/4 min		Short time duty	min						
		Power factor		0.72	0.70	0.76	0.69	0.75	0.81
		Efficiency		0.69	0.75	0.77	0.78	0.78	0.85
		Load	tm/min	7.6	15.4	19.2	30	38	60
	300	Nominal power	kW	1.4	2.9	3.5	5.4	7.2	11
	starts/h	Nominal torque	Nm	3.9	7.7	9.8	15.3	19.2	30
	60 % ED	Nominal speed	RPM	3475	3455	3430	3515	3485	3540
		Short time duty	min						
		Power factor		0.68	0.66	0.70	0.62	0.69	0.75
		Efficiency		0.65	0.74	0.76	0.75	0.78	0.82
		Load	tm/min	6	12	15.4	24	30	48
	300	Nominal power	kW	1.1	2.2	2.9	4.3	5.4	9
	starts/h	Nominal torque	Nm	3	6.1	7.7	12.3	15.3	24
	60 % ED	Nominal speed	RPM	3500	3490	3470	3530	3515	3560
		Short time duty	min						
		Power factor		0.62	0.58	0.63	0.56	0.62	0.70
		Efficiency		0.61	0.70	0.73	0.73	0.75	0.80



For Duty Group 1Am/M4 use the values of Duty Group 2m/M5.

Duty Group Fem/ISO	Q motor data			T7	T8	T9	TA
				MF13ZA200	MF13ZB200	MF13ZC200	MF13X-200
		Rated power	kW	21	27	34	42
		Synchronous speed	RPM	3600	3600	3600	3600
		Brake torque	Nm	130	200	200	200
		Max el. br. torque	Nm				
		El. br. torque	Nm				
		Power fact. start					
		Pull-out torque	Nm	152	190	265	335
		Speed at 80% of pull-out torque	rpm	3300	3260	3210	3250
		Starting torque	Nm				
		Weight	kg	59	72	85	99
		Brake inertia	kgm <sup>2</sup>	0.0017	0.0017	0.0017	0.0017
		Inertia w/o brake	kgm <sup>2</sup>	0.024	0.030	0.036	0.043
2m/M5		Load	tm/min	120	150	192	240
240	300	Nominal power	kW	21	27	34	41
starts/h	starts/h	Nominal torque	Nm	62	76	96	116
40 % ED	60 % ED	Nominal speed	RPM	3480	3470	3470	3470
30/3.5 min		Short time duty	min	30	30	30	30
		Power factor		0.87	0.88	0.88	0.87
		Efficiency		0.87	0.89	0.89	0.89
3m/M6		Load	tm/min	96	120	150	192
300	300	Nominal power	kW	18	21	27	34
starts/h	starts/h	Nominal torque	Nm	48	62	76	96
50 % ED	60 % ED	Nominal speed	RPM	3500	3500	3500	3500
30/4 min		Short time duty	min				
		Power factor		0.85	0.86	0.86	0.86
		Efficiency		0.86	0.89	0.89	0.89
		Load	tm/min	76	96	120	150
	300	Nominal power	kW	14	18	21	27
	starts/h	Nominal torque	Nm	38	48	62	76
	60 % ED	Nominal speed	RPM	3520	3520	3520	3520
		Short time duty	min				
		Power factor		0.81	0.84	0.83	0.84
		Efficiency		0.85	0.89	0.89	0.90
		Load	tm/min	60	76	96	120
	300	Nominal power	kW	11	14	18	21
	starts/h	Nominal torque	Nm	30	38	48	62
	60 % ED	Nominal speed	RPM	3540	3540	3540	3540
		Short time duty	min				
		Power factor		0.75	0.80	0.78	0.80
		Efficiency		0.82	0.89	0.88	0.91



For Duty Group 1Am/M4 use the values of Duty Group 2m/M5.

### 3.7 Motor currents, inverter motors, 100 Hz and 120 Hz

			100 Hz		120 Hz	
Nominal voltage				Current		Current
Used in voltage range				400 V		460
				380...415 V		440...480 V
			tm/min		tm/min	
T1	Current at 80% of pull-out torque	(A)		11.0		11.0
<b>MF10MA200</b>	Nominal current	(A)	10	4.8	12	4.9
			8	4.4	9.6	4.6
			6.3	4.1	7.6	4.1
			5	3.7	6	3.7
	No-load current	(A)		3.2		3.0
T2	Current at 80% of pull-out torque	(A)		17.2		17.2
<b>MF10MB200</b>	Nominal current	(A)	20	9.4	24	9.3
			16	8.3	19.2	8.2
			12.5	7.5	15	7.3
			10	6.9	12	6.6
	No-load current	(A)		6.2		5.7
T3	Current at 80% of pull-out torque	(A)		21.2		21.5
<b>MF10MC200</b>	Nominal current	(A)	25	10.7	30	10.8
			20	9.3	24	9.3
			16	8.3	19.2	8.1
			12.5	7.6	15	7.5
	No-load current	(A)		6.3		5.9
T4	Current at 80% of pull-out torque	(A)		42		42
<b>MF11MA200</b>	Nominal current	(A)	40	18	48	19
			32	15.5	38	17
			25	14.3	30	15.0
			20	13.8	24	14.0
	No-load current	(A)		11.8		11.0
T5	Current at 80% of pull-out torque	(A)		42		42
<b>MF11MB200</b>	Nominal current	(A)	50	21	60	22
			40	18	48	19
			32	15.5	38	17
			25	14.3	30	15.0
	No-load current	(A)		11.8		11.0
T6	Current at 80% of pull-out torque	(A)		78		78
<b>MF13Z-200</b>	Nominal current	(A)	80	31	96	31
			63	25	76	26
			50	23	60	23
			40	20	48	20
	No-load current	(A)		15		14
T7	Current at 80% of pull-out torque	(A)		78		78
<b>MF13ZA200</b>	Nominal current	(A)	100	36	120	37
			80	31	96	31
			63	25	76	26
			50	23	60	23
	No-load current	(A)		15		14
T8	Current at 80% of pull-out torque	(A)		90		93
<b>MF13ZB200</b>	Nominal current	(A)	125	42	150	44
			100	34	120	36
			80	28	96	29
			63	24	76	25
	No-load current	(A)		17		16
T9	Current at 80% of pull-out torque	(A)		125		130
<b>MF13ZC200</b>	Nominal current	(A)	160	55	192	56
			125	45	150	46
			100	39	120	39
			80	34	96	33

			100 Hz		120 Hz	
			Current		Current	
Nominal voltage			400 V		460	
Used in voltage range			380...415 V		440...480 V	
			tm/min		tm/min	
	No-load current	(A)		22		20
TA	Current at 80% of pull-out torque	(A)		157		160
<b>MF13X-200</b>	Nominal current	(A)	200	64	240	65
			160	57	192	56
			125	48	150	48
			100	42	120	41
	No-load current	(A)		26		23

### 3.8 Motor data, one speed motors, 50 Hz

Duty Group Fem/ISO	Q motor data			MF07X-100	MF09ZB100
				OX	OZ
		Rated power	kW	1.5	2.5
		Synchronous speed	RPM	3000	3000
		Brake torque	Nm	12	21
		Max el. br. torque	Nm	-	-
		El. br. torque	Nm	-	-
		Power fact. start		0.83	0.75
		Starting torque	Nm	12	22
		Weight	kg	10	21
		Brake inertia	kgm <sup>2</sup>	0.00006	0.00017
		Inertia w/o brake	kgm <sup>2</sup>	0.0012	0.0039
2m/M5		Load	tm/min	8	13.4
240	240	Nominal power	kW	1.5	2.5
starts/h	starts/h	Nominal torque	Nm	5.4	8.5
40 % ED	40 % ED	Nominal speed	RPM	2700	2850
30/3.5 min		Short time duty	min	30	30
		Power factor		0.79	0.88
		Efficiency		0.63	0.68



For Duty Group 1Am/M4 use the values of Duty Group 2m/M5.

### 3.9 Motor currents, one speed motors, 50 Hz

				Currents			
Nominal voltage				200 V	400 V	500 V	660 V
Used in voltage range				180...220 V	380...415 V	500...525 V	660...690 V
			tm/min				
OX	Starting current	(A)		27	14		
<b>MF07X-100</b>	Nominal current	(A)					
			8	8.7	4.3		
	No-load current	(A)		6.6	4.4		
OZ	Starting current	(A)		64	32		
<b>MF09ZB100</b>	Nominal current	(A)					
			13.4	12.3	6.0		
	No-load current	(A)		6.0	3.0		

### 3.10 Motor data, one speed motors, 60 Hz

Duty Group Fem/ISO	Q motor data			MF07X-100	MF09ZB100
				OX	OZ
		Rated power	kW	1.8	3
		Synchronous speed	RPM	3600	3600
		Brake torque	Nm	12	21
		Max el. br. torque	Nm	-	-
		El. br. torque	Nm	-	-
		Power fact. start		0.83	0.75
		Starting torque	Nm	9	14
		Weight	kg	10	21
		Brake inertia	kgm <sup>2</sup>	0.00006	0.00017
		Inertia w/o brake	kgm <sup>2</sup>	0.0012	0.0039
2m/M5		Load	tm/min	9.6	16
240	240	Nominal power	kW	1.8	3
starts/h	starts/h	Nominal torque	Nm	5.4	8.6
40 % ED	40 % ED	Nominal speed	RPM	2950	3380
30/3.5 min		Short time duty	min	30	30
		Power factor		0.90	0.92
		Efficiency		0.57	0.70



For Duty Group 1Am/M4 use the values of Duty Group 2m/M5.

### 3.11 Motor currents, one speed motors, 60 Hz

				Currents			
Nominal voltage				220 V	380 V	460 V	575 V
Used in voltage range				208...230 V	360...400 V	440...480 V	575...600 V
			tm/min				
OX	Starting current	(A)		25		14	
<b>MF07X-100</b>	Nominal current	(A)					
			9.6	8.7		4.3	
	No-load current	(A)		4.2		4.4	
OZ	Starting current	(A)		60		32	
<b>MF09ZB100</b>	Nominal current	(A)					
			16	12.4		7.0	
	No-load current	(A)		4.3		3.0	

## 4 TRAVELLING MOTORS

### 4.1 One speed, 3000 RPM (100 Hz), 3600 RPM (120 Hz) and 4800 RPM (80Hz)

These motors are driven with fixed voltages and frequencies with the below specified line voltages (=inverter supply voltage). Motor nameplate data is the same for all line voltages. Other voltage/frequency versions are not available for these motors.

Duty type	Motor code		MF06MA100		MF06MA200		MF06LA100		MF06LA200	
	Speed control		inverter		inverter		inverter		inverter	
	Inverter supply voltage		380-480V		380-480V	440-480V	380-480V		380-480V	440-480V
	Motor voltage		400 V		400 V	460 V	400 V		400 V	460 V
	Frequency		80 Hz		100 Hz	120 Hz	80 Hz		100 Hz	120 Hz
	Brake type		compact		compact	compact	compact		compact	compact
	Synchronous speed	RPM	4800		3000	3600	4800		3000	3600
	Brake torque	Nm	2		2	2	2		2	2
	Starting torque	Nm	3.2		3.0	2.9	5.6		7.2	7.1
	Electric braking torque	Nm								
	Starting current	A	6.5		4.2	4.3	10.3		8.2	8.5
	Maximum torque	Nm	3.2		3.0	2.9	5.6		7.2	7.1
	Speed at max. torque	RPM	0		0	0	0		0	0
	80% of max. torque	Nm	2.6		2.4	2.4	4.5		5.7	5.7
	Speed at 80% torque	RPM	3700		2200	2600	3600		2200	2650
	Current at 80% torque	A	3.8		2.1	2.1	6.0		4.8	4.8
	Inertia	kgm <sup>2</sup>	0.0004		0.0004	0.0004	0.0007		0.0007	0.0007
	Inertia with flywheel	kgm <sup>2</sup>								
	Power factor, starting		0.74		0.72	0.70	0.75		0.71	0.69
	Weight with fan	kg								
	Weight	kg	4.9		4.9	4.9	6.8		6.8	6.8
	No-load current	A	1.2		1.0	1.0	1.1		1.6	1.6
	Iron losses	W								
	Stator resistance at 20 °C	Ω	19.5		34	34	12.2		14.7	14.7
	Speed	RPM	4550		2760	3380	4500		2780	3330
	Power	kW	0.45		0.45	0.45	0.9		0.75	0.75
<b>S3-20%</b>	Current	A	2.1		1.4	1.4	2.3		2.3	2.3
	Starting burden	kgm <sup>2</sup> /h								
	Power factor		0.63		0.68	0.63	0.77		0.67	0.67
	Efficiency		0.66		0.66	0.66	0.72		0.74	0.74
	Speed	RPM	4550		2855	3430	4560		2850	3440
	Power	kW	0.45		0.3	0.37	0.65		0.45	0.55
<b>S3-40%</b>	Current	A	2.1		1.2	1.2	2.1		1.8	1.8
	Starting burden	kgm <sup>2</sup> /h								
	Power factor		0.63		0.57	0.59	0.71		0.52	0.53
	Efficiency		0.66		0.65	0.65	0.68		0.73	0.74
	Speed	RPM			2855	3450	4640		2850	3470
	Power	kW			0.3	0.3	0.45		0.45	0.45
<b>S3-60%</b>	Current	A			1.2	1.2	1.8		1.8	1.8
	Starting burden	kgm <sup>2</sup> /h								
	Power factor				0.57	0.59	0.60		0.52	0.52
	Efficiency				0.65	0.65	0.64		0.73	0.73
	Speed	RPM								
	Power	kW								
<b>S3-100%</b>	Current	A								
	Starting burden	kgm <sup>2</sup> /h								
	Power factor									
	Efficiency									

Duty type	Motor code	MF06LA20P		MF06LB100		MF06LB200		
	Speed control	inverter		inverter		inverter		
	Inverter supply voltage	380-480V	440-480V	380-480V		380-480V	440-480V	
	Motor voltage	400 V	460 V	400 V		400 V	460 V	
	Frequency	100 Hz	120 Hz	80 Hz		100 Hz	120 Hz	
	Brake type	compact	compact	DC		DC	DC	
	Synchronous speed	RPM	3000	3600	4800		3000	3600
	Brake torque	Nm	2	2	4		4	4
	Starting torque	Nm	7.2	7.1	10.4		10.5	10.4
	Electric braking torque	Nm						
	Starting current	A	8.2	8.5	16.4		12.9	12.6
	Maximum torque	Nm	7.2	7.1	10.4		11	10.8
	Speed at max. torque	RPM	0	0	0		1480	1770
	80% of max. torque	Nm	5.7	5.7	8.3		8.9	8.9
	Speed at 80% torque	RPM	2200	2650	3350		2350	2820
	Current at 80% torque	A	4.8	4.8	9.0		6.6	6.6
	Inertia	kgm <sup>2</sup>	0.0007	0.0007	0.0006		0.0006	0.0006
	Inertia with flywheel	kgm <sup>2</sup>						
	Power factor, starting		0.71	0.69	0.84		0.77	0.74
	Weight with fan	kg						
	Weight	kg	6.8	6.8	7.8		7.8	7.8
	No-load current	A	1.6	1.6	2.0		2.2	2.0
	Iron losses	W						
	Stator resistance at 20 °C	Ω	14.7	14.7	8.8		10.4	10.4
	Speed	RPM			4450		2720	3320
	Power	kW			1.3		1.3	1.3
<b>S3-20%</b>	Current	A			3.1		3.3	3.2
	Starting burden	kgm <sup>2</sup> /h						
	Power factor				0.82		0.77	0.74
	Efficiency				0.78		0.73	0.76
	Speed	RPM	2800	3360	4500		2770	3370
	Power	kW	0.65	0.75	1.1		1.1	1.1
<b>S3-40%</b>	Current	A	2.1	2.1	2.9		3.0	2.9
	Starting burden	kgm <sup>2</sup> /h						
	Power factor		0.61	0.61	0.78		0.73	0.74
	Efficiency		0.73	0.74	0.78		0.74	0.76
	Speed	RPM			4600		2840	3450
	Power	kW			0.75		0.65	0.65
<b>S3-60%</b>	Current	A			2.3		2.5	2.4
	Starting burden	kgm <sup>2</sup> /h						
	Power factor				0.65		0.60	0.62
	Efficiency				0.75		0.70	0.71
	Speed	RPM						
	Power	kW						
<b>S3-100%</b>	Current	A						
	Starting burden	kgm <sup>2</sup> /h						
	Power factor							
	Efficiency							

Duty type	Motor code		MF07XA100	MF07XB100	MF07XA200	MF07XB200
	Speed control		inverter		inverter	
	Inverter supply voltage		380-480V	380-480V	380-480V	440-480V
	Motor voltage		400 V	400 V	400 V	460 V
	Frequency		80 Hz	80 Hz	100 Hz	120 Hz
	Brake type		DC	DC	DC	DC
	Synchronous speed	RPM	4800	4800	3000	3600
	Brake torque	Nm	16	16	16	16
	Starting torque	Nm	11.7	16.5	13.5	12.7
	Electric braking torque	Nm				
	Starting current	A	23.5	32	19.3	19.4
	Maximum torque	Nm	12	17	17.5	16.5
	Speed at max. torque	RPM	2250	2200	2010	2410
	80% of max. torque	Nm	9.6	13	14	13.1
	Speed at 80% torque	RPM	3770	4050	2620	3140
	Current at 80% torque	A	10.4	14	10	10.6
	Inertia	kgm <sup>2</sup>	0.0012	0.0012	0.0012	0.0012
	Inertia with flywheel	kgm <sup>2</sup>				
	Power factor, starting		0.77	0.79	0.67	0.63
	Weight with fan	kg	13	13	13	13
	Weight	kg				
	No-load current	A	2.6	6.0	2.5	2.3
	Iron losses	W				
	Stator resistance at 20 °C	Ω	5.6	3.75	6.3	6.3
	Speed	RPM	4440	4420	2820	3370
	Power	kW	2.2	3.6	1.8	2.2
<b>S3-20%</b>	Current	A	5.0	8.8	4.3	4.6
	Starting burden	kgm <sup>2</sup> /h				
	Power factor		0.88	0.79	0.79	0.81
	Efficiency		0.74	0.74	0.74	0.75
	Speed	RPM	4520	4460	2850	3430
	Power	kW	1.8	3	1.5	1.8
<b>S3-40%</b>	Current	A	4.3	7.9	3.9	3.9
	Starting burden	kgm <sup>2</sup> /h				
	Power factor		0.84	0.78	0.75	0.76
	Efficiency		0.75	0.74	0.75	0.76
	Speed	RPM	4520	4460	2850	3430
	Power	kW	1.8	3	1.5	1.8
<b>S3-60%</b>	Current	A	4.3	7.9	3.9	3.9
	Starting burden	kgm <sup>2</sup> /h				
	Power factor		0.84	0.78	0.75	0.76
	Efficiency		0.75	0.74	0.75	0.76
	Speed	RPM	4520	4460	2850	3430
	Power	kW	1.8	3	1.5	1.8
<b>S3-100%</b>	Current	A	4.3	7.9	3.9	3.9
	Starting burden	kgm <sup>2</sup> /h				
	Power factor		0.84	0.78	0.75	0.76
	Efficiency		0.75	0.74	0.75	0.76

## 4.2 Two speed, 3000/750 RPM (50Hz) and 3600/900 RPM (60Hz)

Duty type	Motor code	MF06MA104	MF06MA104	MF06LA104	MF06LA104					
	Speed control	2-speed		2-speed						
	Voltage	380V - 415V		440V - 480V						
	Frequency	50 Hz		60 Hz						
	Brake type	DC		DC						
		fast	slow	fast	slow					
	Synchronous speed	RPM	3000	750	3600	900	3000	750	3600	900
	Brake torque	Nm	2	2	2	2	2	2	2	2
	Starting torque	Nm	2.2	1.7	2.2	1.8	3.3	2.5	3.3	2.4
	Electric braking torque	Nm		5.6/2.0		5.6/2.0		8/3.5		8/3.5
	Starting current	A	3.5	1.0	3.9	1.1	5.0	1.4	5.3	1.5
	Maximum torque	Nm	2.2	1.8	2.2	1.8	3.6	2.7	3.5	2.6
	Speed at max. torque	RPM	2150	400	2750	550	1620	380	2220	530
	80% of max. torque	Nm	1.7	1.4	1.7	1.4	2.8	2.1	2.7	2.0
	Speed at 80% torque	RPM	2500	570	3080	740	2100	530	2800	680
	Current at 80% torque	A	1.5	0.8	1.5	0.8	2.3	1.3	2.2	1.3
	Inertia	kgm <sup>2</sup>	0.0004	0.0004	0.0004	0.0004	0.0006	0.0006	0.0006	0.0006
	Inertia with flywheel	kgm <sup>2</sup>								
	Power factor, starting		0.94	0.93	0.91	0.92	0.92	0.93	0.91	0.92
	Weight with fan	kg								
	Weight	kg	5.7	5.7	5.7	5.7	7.8	7.8	7.8	7.8
	No-load current	A	0.9	0.8	0.9	0.8	1.1	1.2	1.1	1.2
	Iron losses	W								
	Stator resistance at 20 °C	Ω	69	280	69	280	50	175	50	175
	Speed	RPM	2800	690	3400	810	2760	660	3340	810
	Power	kW	0.3	0.05	0.37	0.07	0.45	0.1	0.55	0.12
<b>S3-20%</b>	Current	A	1.0	0.8	0.9	0.9	1.3	1.2	1.3	1.2
	Starting burden	kgm <sup>2</sup> /h	2		1.4		3		2.1	
	Power factor		0.7	0.77	0.74	0.78	0.83	0.67	0.82	0.80
	Efficiency		0.67	0.12	0.67	0.12	0.67	0.20	0.67	0.20
	Speed	RPM	2800	690	3400	810	2760	660	3340	810
	Power	kW	0.3	0.05	0.37	0.07	0.45	0.1	0.55	0.12
<b>S3-40%</b>	Current	A	1.0	0.8	0.9	0.9	1.3	1.2	1.3	1.2
	Starting burden	kgm <sup>2</sup> /h	1.5		1.0		2.5		1.9	
	Power factor		0.7	0.77	0.74	0.78	0.83	0.67	0.82	0.80
	Efficiency		0.67	0.12	0.67	0.12	0.67	0.20	0.67	0.20
	Speed	RPM								
	Power	kW								
<b>S3-60%</b>	Current	A								
	Starting burden	kgm <sup>2</sup> /h								
	Power factor									
	Efficiency									
	Speed	RPM								
	Power	kW								
<b>S3-100%</b>	Current	A								
	Starting burden	kgm <sup>2</sup> /h								
	Power factor									
	Efficiency									

Duty type	Motor code		MF07X-104		MF07X-104		MF07XA104		MF07XA104	
	Speed control		2-speed		2-speed		2-speed		2-speed	
	Voltage		380V - 415V		440V - 480V		380V - 415V		440V - 480V	
	Frequency		50 Hz		60 Hz		50 Hz		60 Hz	
	Brake type		DC		DC		DC		DC	
			fast	slow	fast	slow	fast	slow	fast	Slow
	Synchronous speed	RPM	3000	750	3600	900	3000	750	3600	900
	Brake torque	Nm	8	8	8	8	8	8	8	8
	Starting torque	Nm	5.8	5.2	5.6	4.8	7.5	5.4	6.9	5.0
	Electric braking torque	Nm		10/9		10/9		11/9		11/9
	Starting current	A	8.0	2.4	8.0	2.3	9.9	3.1	10	3.1
	Maximum torque	Nm	5.9	5.2	5.7	4.8	7.5	5.4	6.9	5.0
	Speed at max. torque	RPM	1700	0	2040	0	0	0	0	0
	80% of max. torque	Nm	4.6	4.1	4.5	3.8	6	4.3	5.5	4
	Speed at 80% torque	RPM	2400	590	2880	710	2360	505	2830	605
	Current at 80% torque	A	3.9	2.3	3.6	2.3	4.9	2.4	4.7	2.4
	Inertia	kgm <sup>2</sup>	0.0012	0.0012	0.0012	0.0012	0.0012	0.0012	0.0012	0.0012
	Inertia with flywheel	kgm <sup>2</sup>	0.0036	0.0036	0.0036	0.0036	0.0036	0.0036	0.0036	0.0036
	Power factor, starting		0.90	0.80	0.89	0.78	0.89	0.79	0.88	0.76
	Weight with fan	kg								
	Weight with flywheel	kg	13.5	13.5	13.5	13.5	13.5	13.5	13.5	13.5
	No-load current	A	2.2	1.7	1.9	1.7	3.2	2.2	3.0	2.2
	Iron losses	W								
	Stator resistance at 20 °C	Ω	23	75	23	75	19	72	19	72
	Speed	RPM	2720	590	3370	750	2730	590	3310	740
	Power	kW	0.75	0.18	0.9	0.2	0.9	0.2	1.1	0.25
<b>S3-20%</b>	Current	A	2.7	1.9	2.7	1.9	3.5	2.3	3.4	2.3
	Starting burden	kgm <sup>2</sup> /h	7		4.9		7.1		5	
	Power factor		0.80	0.67	0.79	0.64	0.74	0.70	0.77	0.63
	Efficiency		0.57	0.24	0.62	0.26	0.59	0.21	0.62	0.25
	Speed	RPM	2720	590	3370	750	2730	590	3310	740
	Power	kW	0.75	0.18	0.9	0.2	0.9	0.2	1.1	0.25
<b>S3-40%</b>	Current	A	2.7	1.9	2.7	1.9	3.5	2.3	3.4	2.3
	Starting burden	kgm <sup>2</sup> /h	6.5		4.5		6.6		4.6	
	Power factor		0.80	0.67	0.79	0.64	0.74	0.70	0.77	0.63
	Efficiency		0.57	0.24	0.62	0.26	0.59	0.21	0.62	0.25
	Speed	RPM	2720	590	3370	750				
	Power	kW	0.75	0.18	0.9	0.2				
<b>S3-60%</b>	Current	A	2.7	1.9	2.7	1.9				
	Starting burden	kgm <sup>2</sup> /h	5.8		4					
	Power factor		0.80	0.67	0.79	0.64				
	Efficiency		0.57	0.24	0.62	0.26				
	Speed	RPM								
	Power	kW								
<b>S3-100%</b>	Current	A								
	Starting burden	kgm <sup>2</sup> /h								
	Power factor									
	Efficiency									

Duty type	Motor code		MF10M-104		MF10M-104	
	Speed control		2-speed		2-speed	
	Voltage		380V - 415V		440V - 480V	
	Frequency		50 Hz		60 Hz	
	Brake type		DC		DC	
			fast	slow	fast	slow
	Synchronous speed	RPM	3000	750	3600	900
	Brake torque	Nm	21	21	21	21
	Starting torque	Nm	10	8	10	8
	Electric braking torque	Nm		33/13		33/13
	Starting current	A	12.8	3.0	13.7	3.3
	Maximum torque	Nm	10.3	8	10.3	8
	Speed at max. torque	RPM	1380	0	1650	0
	80% of max. torque	Nm	8	6.4	8	6.4
	Speed at 80% torque	RPM	2380	570	2850	680
	Current at 80% torque	A	5.5	1.7	5.6	1.7
	Inertia	kgm <sup>2</sup>	0.0027	0.0027	0.0027	0.0027
	Inertia with flywheel	kgm <sup>2</sup>	0.018	0.018	0.018	0.018
	Power factor, starting		0.83	0.84	0.79	0.81
	Weight with fan	kg				
	Weight with flywheel	kg	26	26	26	26
	No-load current	A	1.3	1.2	1.2	1.2
	Iron losses	W				
	Stator resistance at 20 °C	Ω	13.5	69	13.5	69
	Speed	RPM	2500	585	3200	750
	Power	kW	1.5	0.35	1.8	0.4
<b>S3-20%</b>	Current	A	4.6	1.6	3.8	1.6
	Starting burden	kgm <sup>2</sup> /h	10		6.9	
	Power factor		0.92	0.77	0.91	0.75
	Efficiency		0.62	0.45	0.68	0.50
	Speed	RPM	2700	630	3310	780
	Power	kW	1.3	0.3	1.5	0.35
<b>S3-40%</b>	Current	A	3.0	1.4	3.0	1.4
	Starting burden	kgm <sup>2</sup> /h	8		5.6	
	Power factor		0.89	0.70	0.89	0.68
	Efficiency		0.69	0.47	0.70	0.51
	Speed	RPM	2700	630	3310	780
	Power	kW	1.3	0.3	1.5	0.35
<b>S3-60%</b>	Current	A	3.0	1.4	3.0	1.4
	Starting burden	kgm <sup>2</sup> /h	6		4.2	
	Power factor		0.89	0.70	0.89	0.68
	Efficiency		0.69	0.47	0.70	0.51
	Speed	RPM	2700	630	3310	780
	Power	kW	1.3	0.3	1.5	0.35
<b>S3-100%</b>	Current	A	3.0	1.4	3.0	1.4
	Starting burden	kgm <sup>2</sup> /h	4		2.8	
	Power factor		0.89	0.70	0.89	0.68
	Efficiency		0.69	0.47	0.70	0.51

### 4.3 One speed, 3000 RPM (50Hz) and 3600 RPM (60Hz)

Duty type	Motor code		MF06L-100	MF06L-100
	Speed control		1-speed	1-speed
	Voltage		380V - 415V	440V - 480V
	Frequency		50Hz	60Hz
	Brake type		compact	compact
	Synchronous speed	RPM	3000	3600
	Brake torque	Nm	2	2
	Starting torque	Nm	2.1	2.1
	Electric braking torque	Nm		
	Starting current	A	2.5	2.7
	Maximum torque	Nm	1.8	1.8
	Speed at max. torque	RPM	1830	2550
	80% of max. torque	Nm	1.6	1.6
	Speed at 80% torque	RPM	2180	2790
	Current at 80% torque	A	1.4	1.3
	Inertia	kgm <sup>2</sup>	0.0007	0.0007
	Inertia with flywheel	kgm <sup>2</sup>		
	Power factor, starting		0.79	0.76
	Weight with fan	kg		
	Weight with flywheel	kg	6.8	6.8
	No-load current	A	0.32	0.32
	Iron losses	W		
	Stator resistance at 20 °C	Ω	62	62
	Speed	RPM	2570	3150
	Power	kW	0.3	0.37
<b>S3-20%</b>	Current	A	1.0	1.0
	Starting burden	kgm <sup>2</sup> /h	1.9	1.3
	Power factor		0.83	0.83
	Efficiency		0.57	0.65
	Speed	RPM	2570	3150
	Power	kW	0.3	0.37
<b>S3-40%</b>	Current	A	1.0	1.0
	Starting burden	kgm <sup>2</sup> /h	1.7	1.2
	Power factor		0.83	0.83
	Efficiency		0.57	0.65

## 5 TROLLEY SPEED TABLES

### 5.1 Inverter control(T), Speed range

#### Low headroom trolley, Inverter control

Frame	Rope Reeving	Duty		Gear type	Total ratio	Wheel diameter [mm]	Motor type	Pcs	Inverter power	Speed range [m/min] <sup>1)</sup>			
										Min	380V-415V Max	460V-480V Max	
B	02		M5	M6	GEK 106	34.9	80	MF06MA200	1	MicroMove 007	10	20	24
B	02		M5	M6	GEK 106	34.9	80	MF06MA100	1	MicroMove 007	16	32	32
B	04		M5	M6	GEK 106	34.9	80	MF06MA200	1	MicroMove 007	10	20	24
B	04		M5	M6	GEK 106	34.9	80	MF06MA100	1	MicroMove 007	16	32	32
C	A2		M5	M6	GEK 106	43.7	100	MF06MA200	1	MicroMove 007	10	20	24
C	A2		M5	M6	GEK 106	43.7	100	MF06MA100	1	MicroMove 007	16	32	32
C	A4		M5	M6	GEK 106	43.7	100	MF06MA200	1	MicroMove 007	10	20	24
C	A4		M5	M6	GEK 106	43.7	100	MF06MA100	1	MicroMove 007	16	32	32
C	02	X	M5	M6	GEK 106	43.7	100	MF06LA200	1	MicroMove 007	10	20	24
C	02	X	M5	M6	GEK 106	43.7	100	MF06LA100	1	MicroMove 007	16	32	32
C	04		M5	M6	GEK 106	43.7	100	MF06LA200	1	MicroMove 007	10	20	24
C	04		M5	M6	GEK 106	43.7	100	MF06LA100	1	MicroMove 007	16	32	32
C	04	X			GEK 106	54.8	125	MF06LA200	1	MicroMove 007	10	20	24
C	04	X			GEK 106	54.8	125	MF06LA100	1	MicroMove 007	16	32	32
D	02	X	M5	M6	GEK 106	54.8	125	MF06MA200	2	MicroMove 022	10	20	24
D	02	X	M5	M6	GEK 106	54.8	125	MF06LA100	2	MicroMove 022	16	32	32
D	04		M5	M6	GEK 106	54.8	125	MF06LA200	2	MicroMove 022	10	20	24
D	04		M5	M6	GEK 106	54.8	125	MF06LA100	2	MicroMove 022	16	32	32
D	04	X			GEK 106	54.8	150	MF06LA200	2	MicroMove 022	12.5	25	30
D	04	X			GEK 106	54.8	150	MF06LA100	2	MicroMove 022	20	40	40

<sup>1)</sup> The maximum speed depends on the line voltage. With higher line voltage greater speeds can be achieved.

The table is calculated with maximum loads for the hoists. With derated loads it may be possible to use smaller inverters. In these cases the inverter selection must be verified with KC Drive or Markman.

Normal headroom trolley, Inverter control

Frame	Rope Reeving	Duty		Gear type		Total ratio	Wheel diameter [mm]	Motor type	Pcs	Inverter power	Speed range [m/min] <sup>1)</sup>		
											Min	380V-415V Max	460V-480V Max
B	02		M5	M6	GEK 106	43.7	100	MF06LA200	1	MicroMove 007	10	20	24
B	02		M5	M6	GEK 106	43.7	100	MF06LA100	1	MicroMove 007	16	32	32
B	04		M5	M6	GEK 106	43.7	100	MF06LA200	1	MicroMove 007	10	20	24
B	04		M5	M6	GEK 106	43.7	100	MF06LA100	1	MicroMove 007	16	32	32
C	02		M5	M6	GEK 106	43.7	100	MF06LA200	1	MicroMove 007	10	20	24
C	02		M5	M6	GEK 106	43.7	100	MF06LA100	1	MicroMove 007	16	32	32
C	04		M5	M6	GEK 106	43.7	100	MF06LA200	1	MicroMove 007	10	20	24
C	04		M5	M6	GEK 106	43.7	100	MF06LA100	1	MicroMove 022	16	32	32
C	06		M5	M6	GEK 106	43.7	100	MF06MA200	2	MicroMove 007	10	20	24
C	06		M5	M6	GEK 106	43.7	100	MF06LA100	2	MicroMove 022	16	32	32
C	08		M5	M6	GEK 106	43.7	100	MF06LA200	2	MicroMove 022	10	20	24
C	08		M5	M6	GEK 106	43.7	100	MF06LA100	2	MicroMove 022	16	32	32
D	02/22		M5	M6	GEK 106	43.7	100	MF06MA200	2	MicroMove 022	10	20	24
D	02/22		M5	M6	GEK 106	43.7	100	MF06LA100	2	MicroMove 022	16	32	32
D	04/24		M5	M6	GEK 106	43.7	100	MF06LA200	2	MicroMove 022	10	20	24
D	04/24		M5	M6	GEK 106	43.7	100	MF06LA100	2	MicroMove 022	16	32	32
D	06/26		M5	M6	GEK 106	54.8	125	MF06MA200	4	MicroMove 022	10	20	24
D	06/26		M5	M6	GEK 106	54.8	125	MF06LA100	4	TravelMaster 3 003	16	32	32
D	08/28		M5	M6	GEK 106	54.8	125	MF06MA200	4	MicroMove 022	10	20	24
D	08/28		M5	M6	GEK 106	54.8	125	MF06LA100	4	TravelMaster 3 003	16	32	32
E	02/22	M4	M5	M6	GEK 106	54.8	125	MF06LA200	2	MicroMove 022	10	20	25
E	02/22	M4	M5	M6	GEK 106	54.8	125	MF06LA100	2	MicroMove 022	16	32	32
E	04	M4	M5	M6	GES 320	79.6	180	MF06LA200	3	TravelMaster 3 003	10	20	24
E	04	M4	M5	M6	GES 320	79.6	180	MF06LA100	4	TravelMaster 3 004	16	32	32
E	24	M4	M5	M6	GEK 106	54.8	125	MF06LA200	3	TravelMaster 3 003	10	20	24
E	24	M4	M5	M6	GEK 106	54.8	125	MF06LA100	4	TravelMaster 3 004	16	32	32
E	06/26	M4	M5	M6	GES 320	79.6	180	MF06LA200	3	TravelMaster 3 004	10	20	24
E	06/26	M4	M5	M6	GES 320	79.6	180	MF06LA100	4	TravelMaster 3 005	16	32	32
E	08/28	M4	M5		GES 320	79.6	180	MF06LA200	4	TravelMaster 3 004	10	20	24

<sup>1)</sup> The maximum speed depends on the line voltage. With higher line voltage greater speeds can be achieved.

The table is calculated with maximum loads for the hoists. With derated loads it may be possible to use smaller inverters. In these cases the inverter selection must be verified with KC Drive or Markman.

Double girder trolley, Inverter control

Frame	Rope reeving	Load	End truck	Pcs	Gear	Motor	Inverter	Speed Range [m/min] <sup>1)</sup>			Note
								Min	380V-415V Max	460V-480V Max	
B	02	1.6t 2m	ET 09	1x	GES 342	MF06MA200	MicroMove 007	10	20	24	
B	02	1.6t 2m	ET 09	1x	GES 342	MF06MA100	MicroMove 007	16	32	32	
B	04	3.2t 2m	ET 09	1x	GES 342	MF06MA200	MicroMove 007	10	20	24	
B	04	3.2t 2m	ET 09	1x	GES 342	MF06MA100	MicroMove 007	16	32	32	
C	02	3.2t 1Am	ET 09	1x	GES 342	MF06LA200	MicroMove 007	10	20	24	
C	02	3.2t 1Am	ET 09	1x	GES 342	MF06LA100	MicroMove 007	16	32	32	
C	04	5t 2m	ET 09	1x	GES 342	MF06LA200	MicroMove 007	10	20	24	
C	04	5t 2m	ET 09	1x	GES 342	MF06LA100	MicroMove 007	16	32	32	
C	04	6.3t 1Am	ET 09	1x	GES 342	MF06LA200	MicroMove 007	10	20	24	
C	04	6.3t 1Am	ET 09	1x	GES 342	MF06LA100	MicroMove 022	16	32	32	
C	06	7.5t 2m	ET 11	2x	GES 342	MF06MA200	MicroMove 007	10	20	24	
C	06	7.5t 2m	ET 11	2x	GES 342	MF06LA100	MicroMove 022	20	40	40	
C	08	10t 1Am	ET 11	2x	GES 342	MF06MA200	MicroMove 022	10	20	24	
C	08	10t 1Am	ET 11	2x	GES 342	MF06LA100	MicroMove 022	20	40	40	
D	02/22	6.3t 1Am	ET 11	2x	GES 342	MF06MA200	MicroMove 007	10	20	24	
D	02/22	6.3t 1Am	ET 11	2x	GES 342	MF06LA100	MicroMove 022	20	40	40	
D	04/24	10t 2m	ET 11	2x	GES 342	MF06MA200	MicroMove 022	10	20	24	
D	04/24	10t 2m	ET 11	2x	GES 342	MF06LA100	MicroMove 022	20	40	40	
D	04	12.5t 1Am	ET 11	2x	GES 342	MF06LA200	MicroMove 022	10	20	24	
D	04	12.5t 1Am	ET 11	2x	GES 342	MF06LA100	MicroMove 022	20	40	40	
D	06/26	15t 2m	ET 14	2x	GES 342	MF06LA20P	MicroMove 022	15	32	32	
D	08/28	20t 1Am	ET 14	2x	GES 342	MF06LA20P	TravelMaster 3 003	10	32	32	
D	08/28	20t 1Am	ET 20	2x	GES 490	MF06LB100	TravelMaster 3 003	10	32	32	*
E	02/22	10t 1Am	ET 14	2x	GES 342	MF06LA200	MicroMove 022	16	32	32	
E	04/24	20t 1Am	ET 14	2x	GES 342	MF06LA20P	TravelMaster 3 003	10	25	25	
E	04/24	20t 1Am	ET 20	2x	GES 490	MF06LB100	TravelMaster 3 003	10	32	32	*
E	06/26	30t 1Am	ET 20	2x	GES 490	MF06LA20P	MicroMove 022	10	20	24	
E	06/26	30t 1Am	ET 20	2x	GES 490	MF06LB100	TravelMaster 3 003	10	32	32	
E	08/28	40t 1Am	ET 20	2x	GES 490	MF06LB200	TravelMaster 3 003	10	20	24	
E	08/28	40t 1Am	ET 20	2x	GES 490	MF06LB100	TravelMaster 3 004	10	32	32	
F	22	20t 1Am	ET 20	2x	GES 490	MF06LA200	MicroMove 022	10	20	24	
F	22	20t 1Am	ET 20	2x	GES 490	MF06LB100	TravelMaster 3 003	10	32	32	
F	24	40t 1Am	ET 20	2x	GES 490	MF06LB200	TravelMaster 3 003	10	20	24	
F	24	40t 1Am	ET 20	2x	GES 490	MF06LB100	TravelMaster 3 004	10	32	32	
F	26	60t 1Am	ET 25	2x	GES 590	MF07XA200	TravelMaster 3 005	10	25	25	
F	26	60t 1Am	ET 25	2x	GES 572	MF07XA200	TravelMaster 3 007	10	32	32	
F	28	80t 1Am	ET 25x6	2x	GES 590	MF07XA200	TravelMaster 3 007	10	25	25	
F	28	80t 1Am	ET 25x6	2x	GES 572	MF07XB200	TravelMaster 3 011	10	32	32	

OPTIONAL SPEED

\*) Oversized end truck

<sup>1)</sup> The maximum speed depends on the line voltage. With higher line voltage greater speeds can be achieved.

The table is calculated with maximum loads for the hoists. With derated loads it may be possible to use smaller inverters. In these cases the inverter selection must be verified with KC Drive or Markman.

Contactor control (P), Speeds

Low headroom trolley, Contactor control

Frame	Rope Falls	Duty		Gear type	Motor type	Total ratio	Whl. diam. [mm]	Pcs	50 Hz				60 Hz			
									Max speed		Min speed		Max speed		Min speed	
									Trl Spd [m/min]	Sync. Mot. Speed [rpm]	Trl Spd [m/min]	Sync. Mot. Speed [rpm]	Trl Spd [m/min]	Sync. Mot. Speed [rpm]	Trl Spd [m/min]	Sync. Mot. Speed [rpm]
Z	2		M5 M6	GEK 106PT1B0	MF06MA104	34.9	80	1	20	3000	5	750	24	3600	6	900
Z	4		M5 M6	GEK 106PT1B0	MF06MA104	34.9	80	1	20	3000	5	750	24	3600	6	900
Z	2		M5 M6	GEK 106PT1B0	MF06L-100	34.9	80	1	20	3000		*)	24	3600		*)
Z	4		M5 M6	GEK 106PT1B0	MF06L-100	34.9	80	1	20	3000		*)	24	3600		*)
B	02		M5 M6	GEK 106PT1B0	MF06MA104	34.9	80	1	20	3000	5	750	24	3600	6	900
B	04		M5 M6	GEK 106PT1B0	MF06MA104	34.9	80	1	20	3000	5	750	24	3600	6	900
C	A2		M5 M6	GEK 106PT1B0	MF06MA104	43.7	100	1	20	3000	5	750	24	3600	6	900
C	A4		M5 M6	GEK 106PT1B0	MF06MA104	43.7	100	1	20	3000	5	750	24	3600	6	900
C	02	X	M5 M6	GEK 106PT1B0	MF06MA104	43.7	100	1	20	3000	5	750	24	3600	6	900
C	04	X	M5 M6	GEK 106PT1B0	MF06MA104	43.7	100	1	20	3000	5	750	24	3600	6	900
D	02	X	M5 M6	GEK 106PT1B0	MF06MA104	54.8	125	2	20	3000	5	750	24	3600	6	900
D	04		M5 M6	GEK 106PT1B0	MF06MA104	54.8	125	2	20	3000	5	750	24	3600	6	900
D	04	X		GEK 106PT1B0	MF06LA104	54.8	150	2	24	3000	6	750	29	3600	7	900

\*) One-speed motor

Normal headroom trolley, Contactor control

Frame	Rope Falls	Duty		Gear type	Motor type	Total ratio	Whl. diam. [mm]	Pcs	50 Hz				60 Hz			
									Max speed		Min speed		Max speed		Min speed	
									Trl Spd [m/min]	Sync. Mot. Speed [rpm]	Trl Spd [m/min]	Sync. Mot. Speed [rpm]	Trl Spd [m/min]	Sync. Mot. Speed [rpm]	Trl Spd [m/min]	Sync. Mot. Speed [rpm]
B	02		M5 M6	GEK 106PT1B0	MF06LA104	43.7	100	1	20	3000	5	750	24	3600	6	900
B	04		M5 M6	GEK 106PT1B0	MF06LA104	43.7	100	1	20	3000	5	750	24	3600	6	900
C	02		M5 M6	GEK 106PT1B0	MF06LA104	43.7	100	1	20	3000	5	750	24	3600	6	900
C	04		M5 M6	GEK 106PT1B0	MF06LA104	43.7	100	1	20	3000	5	750	24	3600	6	900
C	06		M5 M6	GEK 106PT1B0	MF06MA104	43.7	100	2	20	3000	5	750	24	3600	6	900
C	08	M4		GEK 106PT1B0	MF06MA104	43.7	100	2	20	3000	5	750	24	3600	6	900
D	02/22		M5 M6	GEK 106PT1B0	MF06MA104	43.7	100	2	20	3000	5	750	24	3600	6	900
D	04/24		M5 M6	GEK 106PT1B0	MF06MA104	43.7	100	2	20	3000	5	750	24	3600	6	900
D	06/26		M5	GEK 106PT1B0	MF06MA104	54.8	125	4	20	3000	5	750	24	3600	6	900
D	08/28	M4		GEK 106PT1B0	MF06MA104	54.8	125	4	20	3000	5	750	24	3600	6	900
E	02/22	M4	M5 M6	GEK 106PT1B0	MF06LA104	54.8	125	2	20	3000	5	750	24	3600	6	900
E	04	M4	M5 M6	GES 320PT3BO	MF06LA104	79.6	180	3	20	3000	5	750	24	3600	6	900
E	24	M4	M5 M6	GEK 106PT1B0	MF06LA104	54.8	125	3	20	3000	5	750	24	3600	6	900
E	06/26	M4	M5 M6	GES 320PT3BO	MF06LA104	79.6	180	3	20	3000	5	750	24	3600	6	900
E	08/28		M5 M6	GES 320PT3BO	MF06LA104	79.6	180	4	20	3000	5	750	24	3600	6	900

**Double girder trolley, Contactor control**

Frame	Rope reeving	Load	End truck	Pcs	Gear		Motor	Speed 50Hz		Speed 60Hz		Note!
								High	Low	High	Low	
B	02	1.6t 2m	ET 9	1x	GES	342	MF06MA104	20	5	24	6	
B	04	3.2t 2m	ET 9	1x	GES	342	MF06MA104	20	5	24	6	
C	02	3.2t 1Am	ET 9	1x	GES	342	MF06MA104	20	5	24	6	
C	04	6.3t 1Am	ET 9	1x	GES	342	MF06LA104	20	5	24	6	
C	06	7.5t 2m	ET 11	2x	GES	342	MF06MA104	20	5	24	6	
C	08	10t 1Am	ET 11	2x	GES	342	MF06MA104	20	5	24	6	
D	02/22	6.3t 1Am	ET 11	2x	GES	342	MF06MA104	20	5	24	6	
D	04/24	12.5t 1Am	ET 11	2x	GES	342	MF06LA104	20	5	24	6	
D	06/26	15t 2m	ET 20	2x	GES	490	MF06LA104	20	5	24	6	*
D	08/28	20t 1Am	ET 20	2x	GES	490	MF06LA104	20	5	24	6	*
E	02/22	10t 1Am	ET 20	2x	GES	490	MF06LA104	20	5	24	6	*
E	04/24	20t 1Am	ET 20	2x	GES	490	MF06LA104	20	5	24	6	*
E	06/26	30t 1Am	ET 25	2x	GES	5B5	MF07X-104	20	5	24	6	*
E	08/28	40t 1Am	ET 25	2x	GES	5B5	MF07X-104	20	5	24	6	*
F	22	20t 1Am	ET 20	2x	GES	490	MF06LA104	20	5	24	6	
F	24	40t 1Am	ET 25	2x	GES	5B5	MF07X-104	20	5	24	6	*
F	26	60t 1Am	ET 25	2x	GES	5B5	MF10M-104	20	5	24	6	
F	28	80t 1Am	ET 25x6	2x	GES	5B5	MF10M-104	20	5	24	6	

\*) Note:Trolley higher than with inverter travelling, consult factory for further information.

## 6 SURFACE TREATMENT

### 6.1 Standard painting system

Product group	Wet painting		Alternative: Powder coating	
	Load carrying steel parts	Outfitting steel parts	Load carrying steel parts	Outfitting steel parts
Parts and components Etc.	End plate Support beam Pulley support Hook forging Hookd side plate Trolley	Cover	End plate Support beam Pulley support Hook forging Hookd side plate Trolley	Cover
Class	C3L		C3L	
Standard/ Painting system	SFS-EN ISO 12944-5 EP120/2-FeSa2½	SFS-EN ISO 12944-5 EP120/2-FeSa2½	SFS-EN ISO 12944-5 PE 80/1	SFS-EN ISO 12944-5 PE 80/1
Steel work	05 (SFS 8145)	05 (SFS 8145)	05 (SFS 8145)	05 (SFS 8145)
Preliminary treatment	Wash, removal of grease Shot blasting Sa2½	Wash, removal of grease Zinc- or ironphosphate	Wash, removal of grease Zinc- or ironphosphate	Wash, removal of grease Zinc- or ironphosphate
Priming paint	Epoxy priming paint 1x60 µm	Epoxy priming paint 1x60 µm		
Finishing paint	Epoxy finishing paint 1x60 µm	Epoxy finishing paint 1x60 µm	Epoxy polyester powder coating 1x80 µm	Epoxy polyester powder coating 1x80 µm
Total paint thickness	120 µm	120 µm	80 µm	80 µm

### 6.2 Color codes

Part	Color code
	<b>S</b>
<b>Hoisting unit</b>	
Hoist frame	RAL 7021
Frame cover	RAL 9006
Hoist motor (frame)	Aluminum
Hoist motor (fan cover)	RAL 7021
Hoist gear (frame)	RAL 7021
<b>Junction box</b>	
Plastic	RAL 7016
Steel	RAL 7021
<b>Rope reeving</b>	
Hook forging	RAL 7021
Cross bar	RAL 7021/Zincd
Hook sheave cover plate	RAL 1021
Locking plate	RAL 7021
Sheave	RAL 7021
Sheave support	RAL 7021
Rope guide	RAL 7021
<b>Electrical cubicle</b>	
Cubicle bottom	RAL 7021
Cubicle cover (QA/QB-L/N)	RAL 9006
Cubicle cover (others)	RAL 9006
Cubicle support (Low headroom)	RAL 7021
Back plate (Low headroom)	RAL 9006
Counterweight	RAL 7021
<b>Trolley</b>	
All Trolley types	RAL 7021
<b>Travelling machinery</b>	
Travel motor (frame)	Anodised (black)
Travel gear (frame)	RAL 7021
Travel wheel	RAL 7021
<b>Color</b>	
RAL 1021	Cadmium yellow
RAL 7016	Dark grey
RAL 7021	Black grey
RAL 9006	White aluminium
DZ 2369	Green peppermint

## 7 WIRE ROPE DATA

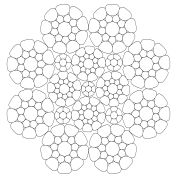

Cross section  
Rope type: A

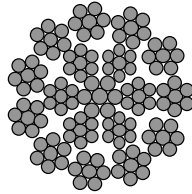

Cross section  
Rope type: B

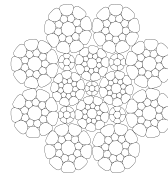

Cross section  
Rope type: D and Dr

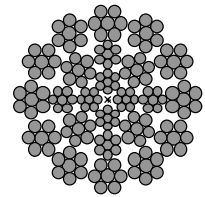

Cross section  
Rope type: F and Y

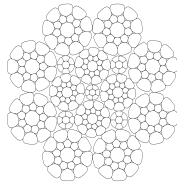

Cross section  
Rope type: G and Gr

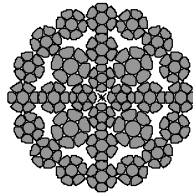

Cross section  
Rope type: J, Z and M

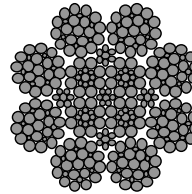

Cross section  
Rope type: K and Kr

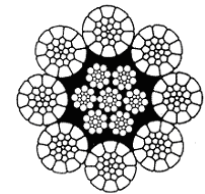

Cross section  
Rope type: C, E, Er, H, Hr, L, Lr

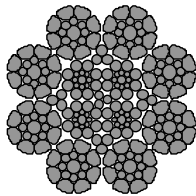

Cross section  
Rope type: N

Rope	Dia. mm	Minimum Breaking Load kN	Calculated Breaking Load kN	Strand Constr.	Wire Strength N/mm <sup>2</sup>	Core	Rope Lay	Comp. Outer Strands	Wire Material	Weight kg/m	Rot. resist.
N	6.2	36.4	45.5	8 x 17	2160	Steel core parallel strands	LO	Yes	Galvanized steel	0.17	No
A	6.4	43.7	51.4	8 x 19	2160	Steel core parallel strands	LO	Yes	Galvanized steel	0.2	No
B	6.7	37.0	47.4	17 x 7	2160	Steel core	LO	No	Galvanized steel	0.18	Yes
D	8	68.9	81.1	8 x 19	2160	Steel core parallel strands	LO	Yes	Galvanized steel	0.33	No
Dr	8	68.9	81.1	8 x 19	2160	Steel core parallel strands	RO	Yes	Galvanized steel	0.33	No
F	8	56.0	66.0	24 x 7	2160	Steel core	LL	No	Galvanized steel	0.27	Yes
Y	8.5	63.5	80.0	24 x 7	2160	Steel core	LL	No	Galvanized steel	0.32	Yes
G	11	127.2	149.7	8 x 19	2160	Steel core parallel strands	LO	Yes	Galvanized steel	0.62	No
Gr	11	127.2	149.7	8 x 19	2160	Steel core parallel strands	RO	Yes	Galvanized steel	0.62	No
J	11	115.0	137.3	28 x 7	2160	Steel core	LO	Yes	Galvanized steel	0.56	Yes
Z	11.5	125.0	150.3	28 x 7	2160	Steel core	LO	Yes	Galvanized steel	0.61	Yes
K	15	221.6	257.5	8 x 25	2160	Steel core parallel strands	LO	No	Galvanized steel	1.03	No
Kr	15	221.6	257.5	8 x 25	2160	Steel core parallel strands	RO	No	Galvanized steel	1.03	No
M	15	218	249.0	28 x 7	2160	Steel core	LO	Yes	Galvanized steel	1.03	Yes
C	6.5	36.7	43.2	8 x 19	1960	Independent wire rope core	LO	Yes	Galvanized steel	0.2	No
E	8	65.6	78.1	8 x 19	2160	Independent wire rope core	LO	Yes	Galvanized steel	0.33	No
Er	8	65.6	78.1	8 x 19	2160	Independent wire rope core	RO	Yes	Galvanized steel	0.33	No
H	11	128	152	8 x 19	2160	Independent wire rope core	LO	Yes	Galvanized steel	0.63	No
Hr	11	128	152	8 x 19	2160	Independent wire rope core	RO	Yes	Galvanized steel	0.63	No
L	15	229	273	8 x 26	2160	Independent wire rope core	LO	Yes	Galvanized steel	1.14	No
Lr	15	229	273	8 x 26	2160	Independent wire rope core	RO	Yes	Galvanized steel	1.14	No

LO = left hand ordinary lay, RO = right hand ordinary lay, LL = left hand Lang's lay

## 8 MATERIALS

F I G U R E	Part	Fabrication method							Material									Material		Standard finishing				
		1	2	3	4	5	6	7	1	2	3	4	5	6	7	8	9	Description	Standard	1	2	3	4	
		1 Cast							1 Steel											1 Epoxy paint				
		2 Forged							2 Steel plate											2 Zinc elektroplating				
		3 Extruded							3 Case-hardening steel											3 Anodised				
		4 Stamped							4 Quenched and tempered steel											4 Nitrated				
		5 Flame cut							5 Spherical cast iron															
		6 Machined							6 Grey cast iron															
		7 Hardened							7 Acid-proof steel															
									8 Aluminium															
									9 Plastic / rubber															
<b>FA/B</b>	<b>HOIST FRAME</b>																							
A4	Drum						•	•										S355J2	EN10025					
B6	Drum Cover																•	POM						
B3	Drum seal ring																•	POM						
	Sealing																•	Felt PL3						
A7	Rope guide	•					•							•				EN-GJS-500-7	EN1563	•				
	Rope Guide, Plate, Z																•	POM						
B4	Frame rods						•	•	S355J2									EN10025		•				
A1	Frame ends, A,B,C				•			•	S355MC									EN10149		•				
	Frame ends, D,E				•		•	•	S355J2									EN10025		•				
	Frame protection cover				•			•	DC01									EN10130		•				
B2	Bearing part, A,B,C,Z																•	POM						
B1	Slide Part																•	PE-UHMW						
A3	Junction box																•	PBT/PC	Pocan					
	Junction box seal																•	PUR						
	Cable duct																•	PA6						
	Cable duct clamp																•	PA						
<b>FC</b>	<b>HOOK BLOCK</b>																							
	Hook forging		•				•		34CrMo4					•				EN10083		•				
C1	Hook forging		•				•		34CrNiMo6					•				EN10083		•				
C2	Hook block housing, A,B,C, when 04 rope falls				•			•	S355MC									EN10149		•				
C2	Cross bar						•	•	S355J2									EN10025		•				
C3	Sheave cover				•			•	DC03									EN10130		•				
<b>FC</b>	<b>ROPE SHEAVE BLOCK</b>																							
C4	Rope sheaves	•					•		EN-GJS-700-3					•				EN1563		•				
C5	Rope sheave shafts						•	•	S355J2									EN10025			•			
C6	Suspension beam					•	•	•	S355J2									EN10025			•			
<b>FD</b>	<b>ROPE ANCHORAGE</b>																							
D1	Rope clamps						•	•	S355J2									EN10025			•			
D2	Wedge housing	•							EN-GJS-500-7					•				EN1563		•				
D3	Wedge	•							EN-GJS-500-7					•				EN1563		•				
D4	Wedge housing shaft						•		S355J2					•				EN10025						
<b>FD</b>	<b>OVERLOAD DEVICE</b>																							
D5	Beam							•	S355J2									EN10025			•			
D6	U-Beam							•	S235J2									EN10025			•			
D7	Bearing							•	S355J2									DIN2448			•			
D8	Fixing plate, D,E							•	DC01									EN10131			•			
D9	Limit switch mechanical																•	PC,PVC						
D10	Limit switch back up																•	fibre reinforced PA, POM						





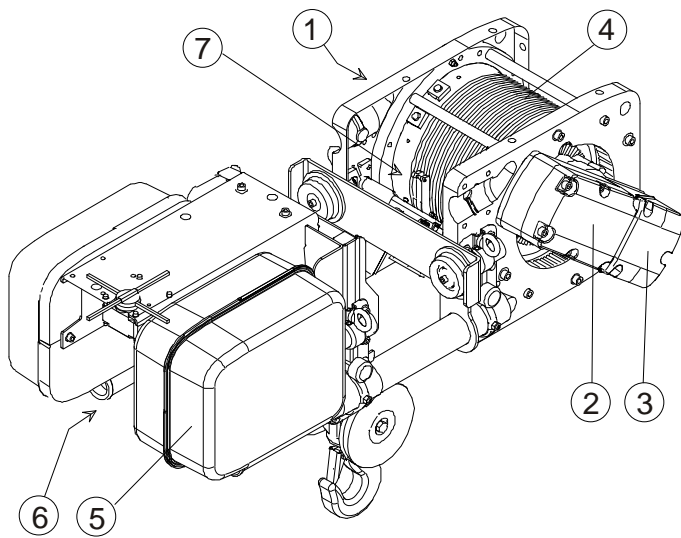

Figure A

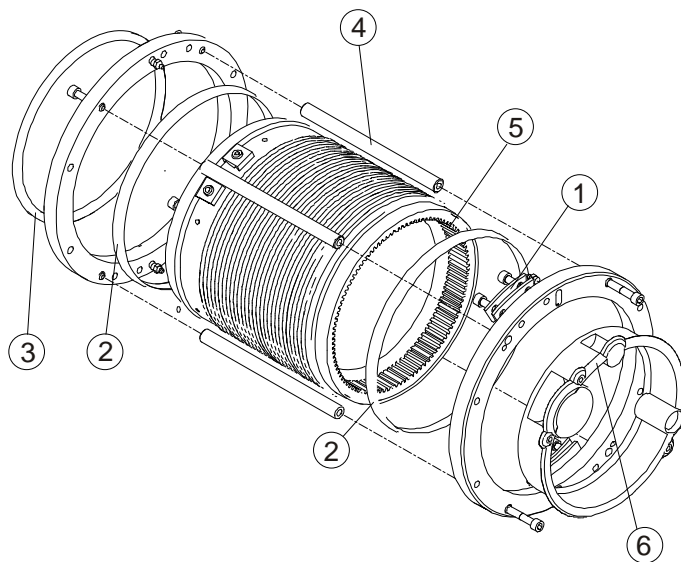

Figure B

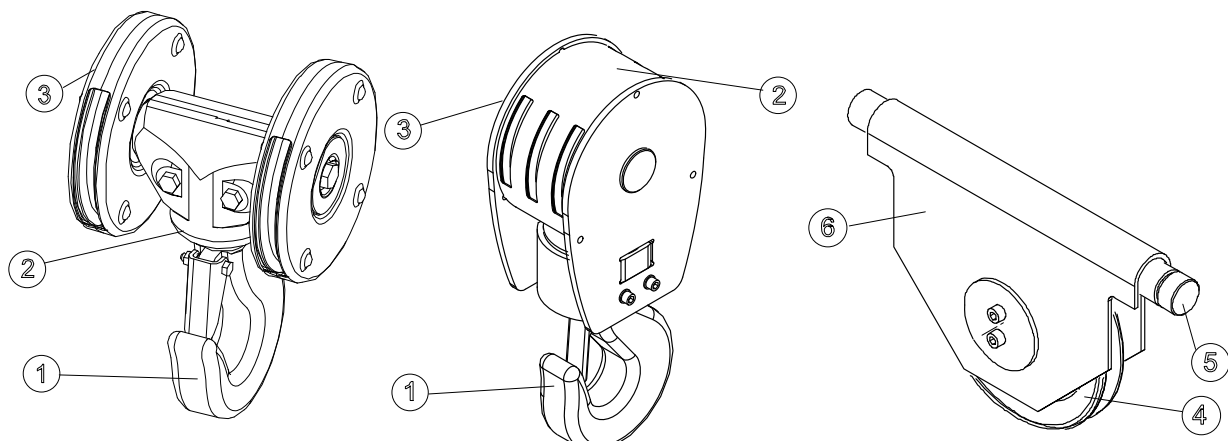

Figure C

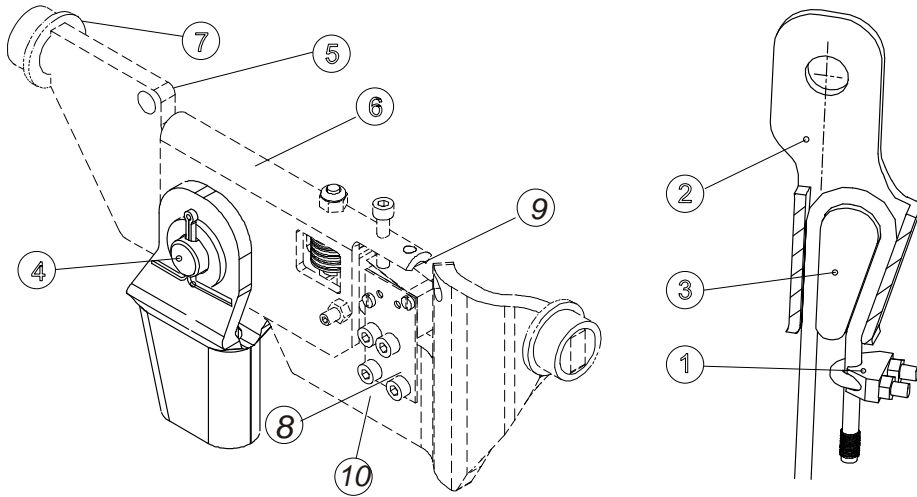

Figure D

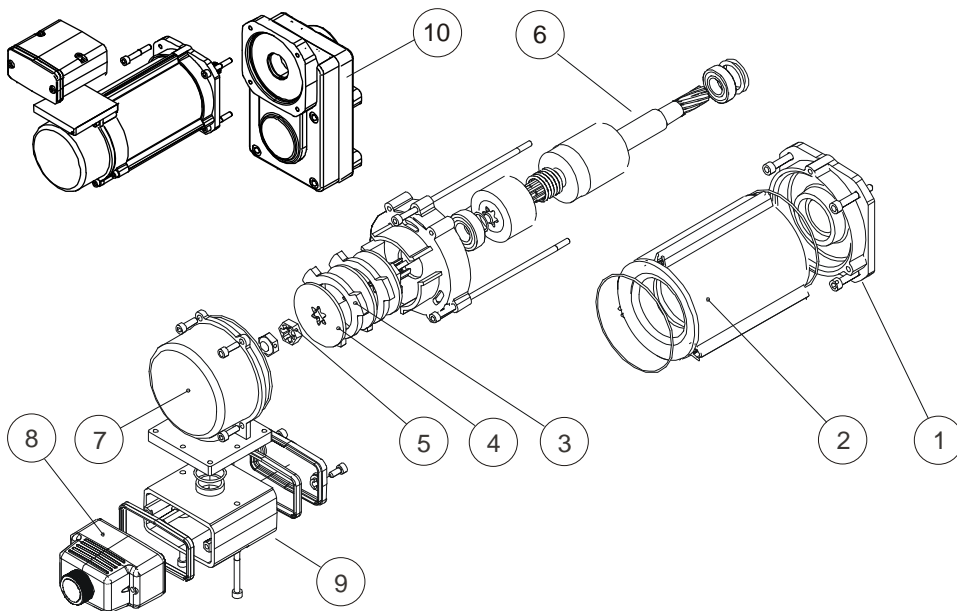

Figure E

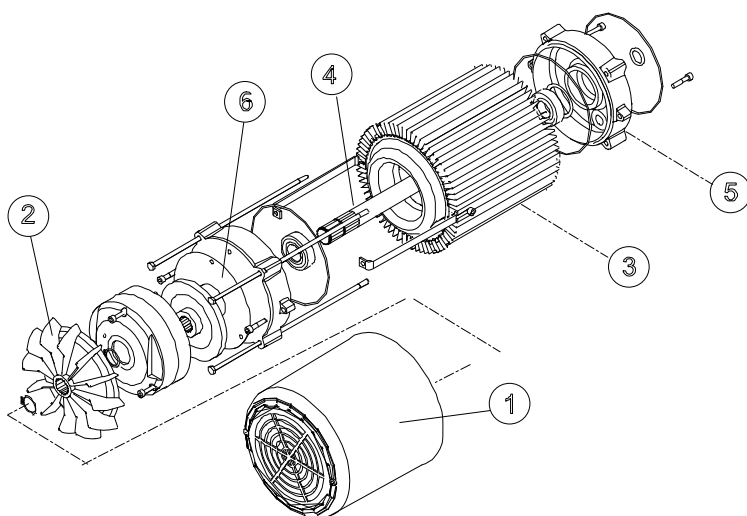

Figure F

## 9 HOOK

### 9.1 Hook block dimensions

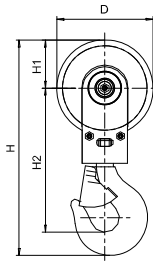

Figure 1

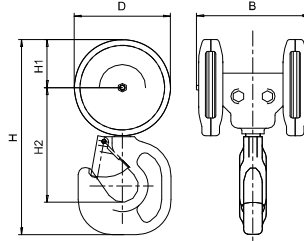

Figure 2

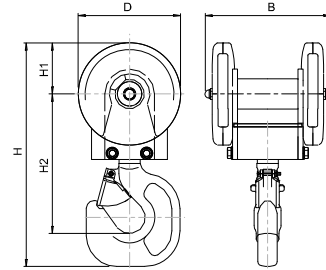

Figure 3

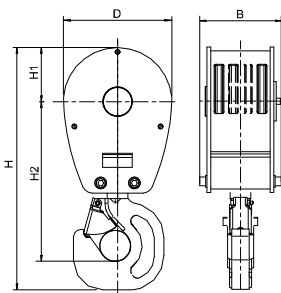

Figure 4

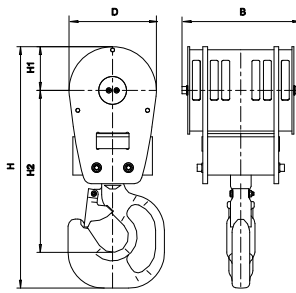

Figure 5

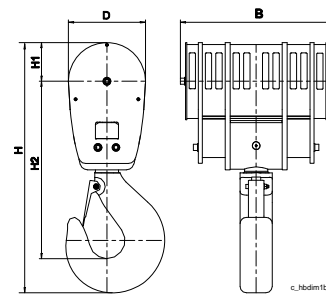

Figure 6

Hoist frame	Rope falls	Hoist duty			Hook forging	Fig.	Hook block dimensions (mm)					Weight (kg)
		1Am/M4	2m/M5	3m/M6			H	H1	H2	D	B	
Z	02		M5		RSN1 V	1	385	84	261	168	108	9.3
Z	04		M5		RSN1.6 V	3	391	84	258	168	202	16.2
B	02		M5	M6	RSN 1 V	1	385	84	261	168	108	9.3
B	04		M5	M6	HBC 1.6 V	2	337	84	198	168	221	13
C	02	X (M4)	M5	M6	RSN 1 V	1	425	102	282	204	118	14
C	04		M5	M6	HBC 2.5 V	2	426	102	259	204	270	22
C	04	X (M4)			HBC 2.5 V	3	443	102	276	204	241	31.5
C	06		M5	M6	HBC 2.5 V	4	499	110	324	220	165	37
C	08	M4	M5		HBC 2.5 V	4	499	110	324	220	165	40
D	02	X (M4)	M5	M6	HBC 2.5 V	1	578	142	371	283	148	31
D	04		M5	M6	HBC 5 V	2	548	142	316	283	376	46.5
D	04	X (M4)			HBC 5 V	3	604	142	372	283	341	77.5
D	06		M5	M6	HBC 5 V	4	687	150	447	300	220	88
D	08	M4	M5		HBC 5 V	4	687	150	447	300	220	95
D	22		M5	M6	HBC 2.5 V	4	499	110	324	220	165	29
D	24		M5	M6	HBC 5 V	5	608	110	408	220	220	67
D	26		M5	M6	RSN 6 V	5	644	110	448	220	286	80
D	28	M4	M5		RSN 6 V	5	644	110	448	220	344	88
E	02	M4	M5	M6	HBC 5 V	4	788	198	500	395	226	95
E	04	M4	M5	M6	HBC 5 V	4	788	198	500	395	226	107
E	06	M4	M5	M6	RSN10 T	4	930	198	625	395	259	182
E	08	M4	M5		RSN 16 T	5	1067	198	735	395	289	259
E	22	M4	M5	M6	HBC 5 V	4	687	150	447	300	224	90
E	24	M4	M5	M6	HBC 5 V	4	717	170	457	340	271	125
E	26	M4	M5	M6	RSN10 T	5	862	170	585	340	405	240
E	28	M4	M5		RSN 16 T	6	999	170	695	300	487	306
F	22	M4	M5	M6	HBC 5 V	4	788	198	500	395	219	107
F	24	M4	M5	M6	RSN 16 T	5	1114	228	753	455	335	309
F	26	M4	M5	M6	RSN 20 T	5	1201	228	822	455	487	485
F	28	M4	M5		RSN 25 T	6	1285	228	886	455	579	587

## 9.2 Hook block dimensions

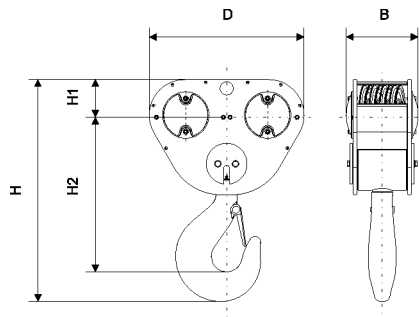

Figure 7

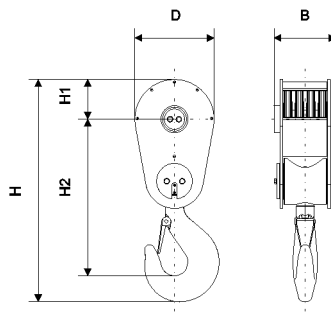

Figure 8

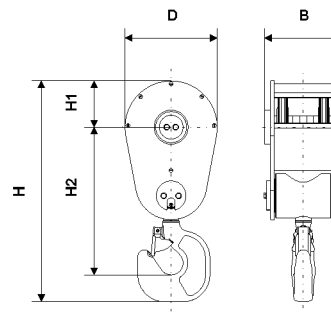

Figure 9

Hoist frame	Rope falls	Hoist duty			Hook forging	Fig.	Hook block dimensions (mm)					Weight (kg)
		1Am/M4	2m/M5	3m/M6			H	H1	H2	D	B	
E	02	M4	M5	M6	HBC 5 V	9	830	205	535	410	280	98
E	04	M4	M5	M6	HBC 5 V	9	830	205	535	410	280	111
E	06	M4	M5	M6	RSN10 T	8	996	205	684	410	314	181
E	08	M4	M5		RSN 16 T	8	1126	205	787	410	322	236
E	22	M4	M5	M6	HBC 5 V	9	740	155	495	310	259	78
E	24	M4	M5	M6	RSN 6 V	7	719	160	473	700	312	143
E	26	M4	M5	M6	RSN10 T	7	861	160	594	700	316	192
E	28	M4	M5		RSN 16 T	7	981	160	687	700	324	299
F	22	M4	M5	M6	RSN 6 V	8	844	205	553	410	280	114
F	24	M4	M5	M6	RSN 16 T	7	1041	200	707	910	393	332
F	26	M4	M5	M6	RSN 20 T	7	1130	200	778	910	402	495
F	28	M4	M5		RSN 25 T	7	1224	200	852	910	411	603



Note: These hook blocks enter production in 2010. Consult the factory for availability.

### 9.3 Hook forging dimensions

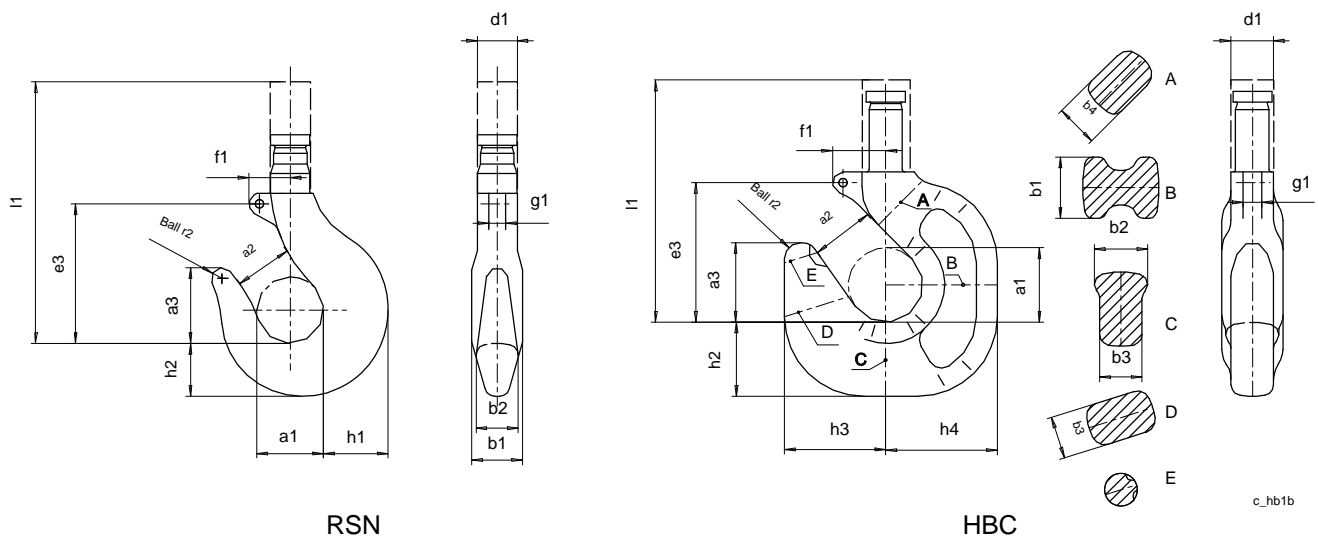

	RSN										HBC		
	RSN 1	RSN 1.6	RSN 2.5	RSN 4	RSN 5	RSN 6	RSN 10	RSN 16	RSN 20	RSN 25	HBC 1.6	HBC 2.5	HBC 5
a <sub>1</sub>	50 + 3	56 + 3	63 + 3	71 + 4	80 + 4	90 + 5	112 + 6	140 + 6	160 + 8	180 + 8	56 + 3	63 + 3	80 + 3
a <sub>2</sub>	40 + 3	45 + 3	50 + 3	56 + 4	63 + 4	71 + 5	90 + 6	112 + 6	125 + 8	140 + 8	45 + 3	51 + 3	63 + 3
a <sub>3</sub>	57 + 3	64 + 3	72 + 3	80 + 4	90 + 4	101 + 5	127 + 6	160 + 6	180 + 8	202 + 8	60 + 3	65 + 3	84 + 3
b <sub>1</sub>	38 + 3	45 + 3	53 + 3	63 + 4	71 + 4	80 + 5	100 + 6	125 + 6	140 + 8	160 + 8	46 + 3	52 + 3	75 + 3
b <sub>2</sub>	32 + 3	38 + 3	45 + 3	53 + 4	60 + 4	67 + 5	85 + 6	106 + 6	118 + 8	132 + 8	40 + 3	44 + 3	64 + 3
b <sub>3</sub>	+	+	+	+	+	+	+	+	+	+	32 + 3	37 + 3	59 + 3
b <sub>4</sub>	+	+	+	+	+	+	+	+	+	+	32 + 3	37 + 3	45 + 2
d <sub>1</sub>	30 + 3	36 + 3	42 + 3	48 + 4	53 + 4	60 + 5	75 + 6	95 + 6	106 + 8	118 + 8	38 + 3	44 + 3	55 + 3
e <sub>3</sub>	105 + 3	118 + 3	132 + 3	148 + 4	165 + 4	185 + 5	221 + 6	280 + 6	330 + 8	360 + 8	105 + 3	118 + 3	148 + 3
f <sub>1</sub>	31 + 1	35 + 1	40 + 1	45 + 2	51 + 2	57 + 2	46 + 3	58 + 3	68 + 3	74 + 3	40 + 1	45 + 2	56 + 2
g <sub>1</sub>	12.5 + 1	14 + 1	16 + 1	16 + 2	18 + 2	18 + 2	23 + 3	33 + 3	33 + 3	38 + 3	14 + 1	16 + 1	18 + 2
h <sub>1</sub>	48 + 3	56 + 3	67 + 3	80 + 4	90 + 4	100 + 5	125 + 6	160 + 6	180 + 8	200 + 8	+	+	+
h <sub>2</sub>	40 + 3	48 + 3	58 + 3	67 + 4	75 + 4	85 + 5	106 + 6	132 + 6	150 + 8	170 + 8	56 + 3	65 + 3	90 + 4
h <sub>3</sub>	+	+	+	+	+	+	+	+	+	+	76 + 3	85 + 3	112 + 4
h <sub>4</sub>	+	+	+	+	+	+	+	+	+	+	84 + 3	100 + 3	130 + 4
l <sub>1</sub>	197 + 3	224 + 3	253 + 3	285 + 4	318 + 4	380 + 5	452 + 6	582 + 6	653 + 8	724 + 8	199 + 3	260 + 3	300 + 4
r <sub>2</sub>	50 + 3	56 + 3	63 + 3	71 + 4	90 + 4	90 + 5	112 + 6	140 + 6	160 + 8	180 + 8	56 + 3	63 + 3	80 + 4
weight (forging) kg	3.2	4.5	6.3	8.8	12.3	17.1	34	66	95	136	5.1	8	15

Note: Safety latch on HBC forging decreases dimension a<sub>2</sub> about 5 mm and about 15 mm on RSN forging.

Note: The '+ number' after the nominal dimension indicates the tolerance. For example 160+6 means that the actual dimension is between 160 - 166 mm.

	Hook forging standard	
	RSN	HBC
Dimension standard	DIN 15401	DIN 15401 when applicable
Material standard	DIN 15400	DIN 15400

## 10 DRUM AND ROPE SHEAVE DIAMETERS

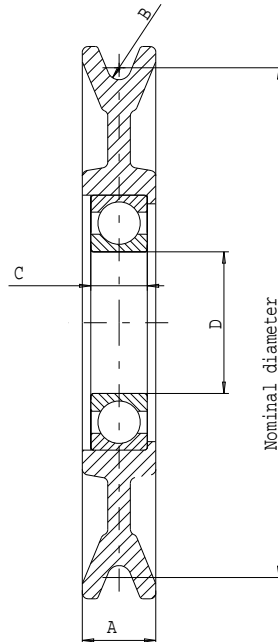

Rope sheave diameters	Rope diameter	Duty class	A	B	C	D
(nominal, mm)	(nominal, mm)	FEM / ISO	(mm)	(mm)	(mm)	(mm)
146	6.4	3m / ISO M6	22 / 22	3.3	18	40
180	8	3m / ISO M6	26 / 26	4.2	20	50
248	11	3m / ISO M6	32 / 38	5.8	23	65
288 <sup>(1)</sup>	11	4m / ISO M7	32 / 48	5.8	33	65
338	15	3m / ISO M6	40 / 46	8	28	85
398 <sup>(1)</sup>	15	4m / ISO M7	40 / 59	8	41	85

<sup>1)</sup> Standard as center wheels on some true-vertical lift hooks.

Frame size code	Rope diameter (mm)	Reeving	Rope drum diameter (nominal, (mm))	Rope drum pitch (mm)	Rope sheave diameter (nominal, mm)	Number of rope clamps on drum
Z	6.2	Standard	243	7	146	2
B	6.4	Standard	303	7.2	146	2
C	8	Standard	355	9.1	180	3
D	11	Standard	406	12.5	248	4
D	8	True vertical	406	9.1	180	2x3
E	15	Standard	608	17.1	338	6
E	11	True vertical	608	12.5	248 and 288	2x4
F	15	True vertical	608	17.1	338 and 398	2x6

